

CDL 60Hz

Light Vertical Multistage Centrifugal Pump

CDLF



XRISE New Energy Technology co., Ltd
Add: Building 1, Industrial Park, South of
Baogong Avenue, Yaohai District, Hefei, Anhui, China
Contract: +86 17856275957
Call: +551 6467 6468

E170411
Code1500041177
subject to amendments



Content

General Data

Performance scope	4
Product range	5
Pump	6
Max. working pressure	7
Max. Ambient temperature	7
Curve illustration	8
Performance curve	8
Min. Inlet pressure NPSH	9
Operation in parallel	9
Material	10

Technical Data

CDL/CDLF1,60Hz	14
CDL/CDLF2,60Hz	16
CDL/CDLF3,60Hz	18
CDL/CDLF4,60Hz	20
CDL/CDLF5,60Hz	22
CDL/CDLF8,60Hz	24
CDL/CDLF10,60Hz	26
CDL/CDLF12,60Hz	28
CDL/CDLF15,60Hz	30
CDL/CDLF16,60Hz	32
CDL/CDLF20,60Hz	34
CDL/CDLF32,60Hz	36
CDL/CDLF42,60Hz	38
CDL/CDLF65,60Hz	40
CDL/CDLF85,60Hz	42
CDL/CDLF120,60Hz	44
CDL/CDLF150,60Hz	46
CDL/CDLF200,60Hz	48

Performance scope

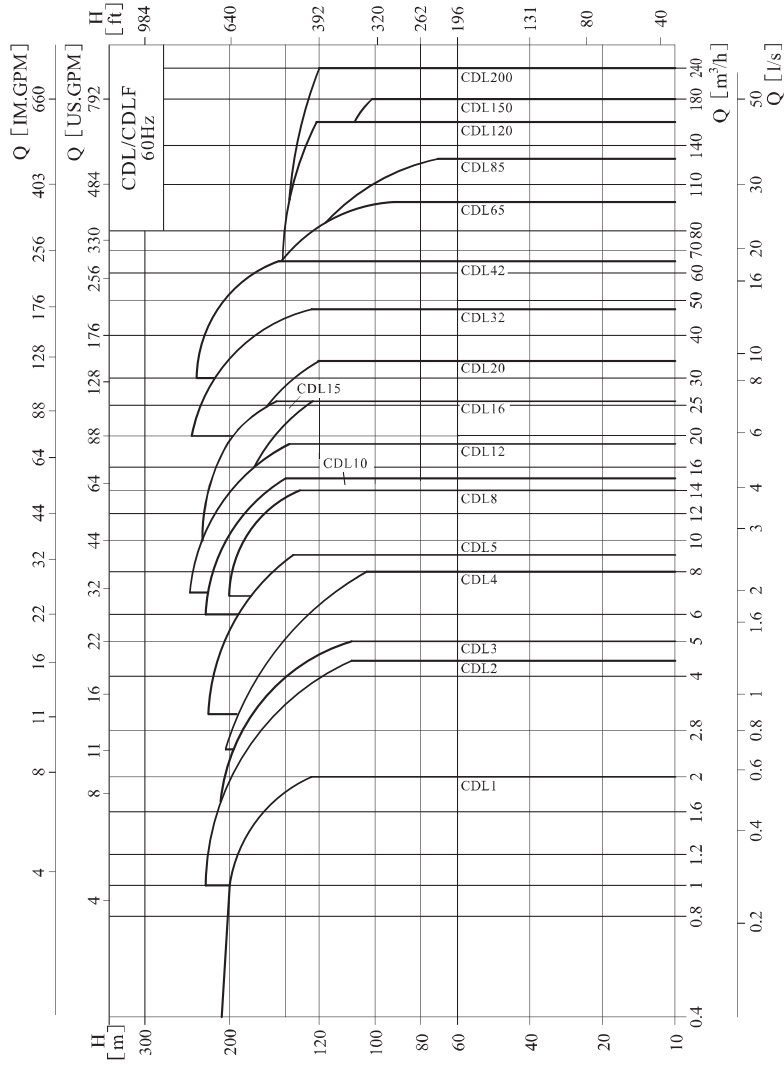

Product range

Description	CDL1	CDL2	CDL3	CDL4	CDL5	CDL8	CDL10	CDL12	CDL15	CDL16	CDL20	CDL32	CDL42	CDL65	CDL85	CDL120	CDL150	CDL200	
Rate flow[m³/h]	1	2	3	4	5	8	10	12	15	16	20	32	42	65	85	120	150	200	
Rate flow[l/s]	0.28	0.56	0.83	1.1	1.39	2.2	2.78	3.3	4.2	4.4	5.6	8.9	11.7	18	24	33	41.6	55.6	
Flow range(m³/h)	0.6-2	1-4.5	1.5-5	2.5-8	3-9	7-14	6-15	7-19	10-26	10-26	12-34	20-48	30-65	40-100	60-130	60-160	80-180	100-240	
Flow range[l/s]	0.17-0.56	0.28-1.25	0.42-1.4	0.7-2.2	0.83-2.5	1.9-3.9	1.67-4.17	1.9-5.3	2.8-7.2	3.3-9.4	5.5-13.3	8.3-18	11.1-27.7	16.7-36.1	22.5-44.4	27.8-66.7	33-75	41.6-93	
MAX.pressure[bar]	22	23.5	23	21	2	20	25	25	20	20	25	26	26	18	15	15	14	15	
Motor power[kW]	0.37-3	0.55-4	0.37-4	0.75-5.5	0.55-7.5	0.75-11	0.75-11	1.1-15	1.5-18.5	2.2-18.5	3-30	5.5-45	7.5-45	11-45	18.5-75	15-75	30-110		
Temp[°C]	-15--+120																		
MAX. efficiency[%]	44																		
Type	CDL																		
CDL	●	●	●	●	●	●	●	●	●	●	●	●	●	●	●	●	●	●	●
CDLF	●	●	●	●	●	●	●	●	●	●	●	●	●	●	●	●	●	●	●
CDLF Pipelines	●																		
DIN Flange	DN25	DN25	DN25	DN32	DN32	DN40	DN40	DN50	DN50	DN50	DN50	DN65	DN80	DN100	DN100	DN125	DN125	DN150	
Oval Flange	G1	G1	G1	G1½	G1½	G1½	G1½	G1½	G1½	G1½	G1½	G1½	G1½	G1½	G1½	G1½	G1½	G1½	
CDLF Pipelines	●																		
DIN Flange	DN25	DN25	DN32	DN32	DN32	DN40	DN40	DN50	DN50	DN50	DN50	DN65	DN80	DN100	DN100	DN125	DN125	DN150	
Cutting female joint	DN32	DN32	DN32	DN32	DN32	DN50	DN50	DN50	DN50	DN50	DN50								
Pipe thread	ZG1½	ZG1½	ZG1½	ZG1½	ZG1½	ZG2	ZG2	ZG2	ZG2	ZG2	ZG2	ZG2	ZG2	ZG2	ZG2	ZG2	ZG2	ZG2	
Oval Flange	G1	G1	G1	G1½	G1½	G1½	G1½	G1½	G1½	G1½	G1½	G1½	G1½	G1½	G1½	G1½	G1½	G1½	

● Pump

CDL / CDF is a kind of vertical non-self priming multistage centrifugal pump, which is driven by a standard electric motor. The motor output shaft directly connects with the pump shaft through a coupling. The pressure-resistant cylinder and flow passage components are fixed between pump head and inlet & outlet section with stay bolts. The inlet and outlet are located at the pump bottom at the same plane. This kind of pump can be equipped with an intelligent protector to effectively prevent it from dry-running, out-of-phase and overload.

● Motor

- Full-enclosed air-blast two-pole standard motor
- Protection class: IP55
- Insulation class: F
- Standard voltage: 60Hz: 3 × 200-230 / 346-400V
3 × 220-255 / 380-440V
3 × 220-277 / 380-480V

● Definition of Model

CDL/CDF1,2,3,4,5,8,10,15,12,16 and 20

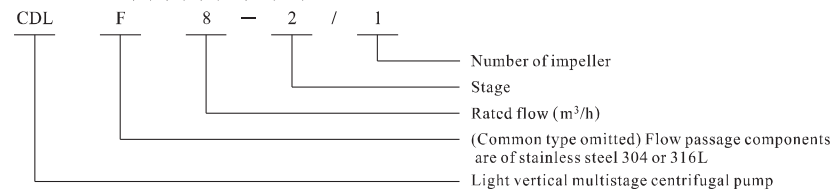

CDL/CDF32,42,65,85,120,150 and 200

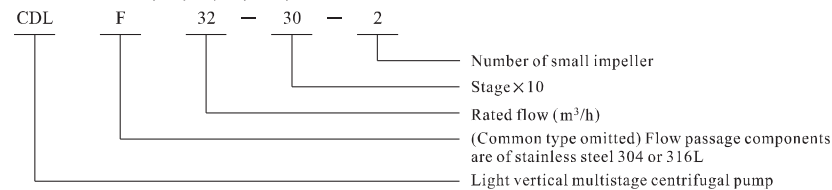

● Application

CDL / CDF is a kind of multifunctional products. It can be used to convey various medium from tap water to industrial liquid at different temperature and with different flow rate and pressure. CDL type is applicable to conveying non-corrosive liquid, while CDF is suitable for slightly corrosive liquid.

- Water supply: Water filter and transport in Waterworks, boosting of main pipeline, boosting in high-rise buildings.
- Industrial boosting: Process flow water system, cleaning system, high-pressure washing system, fire fighting system.
- Industrial liquid conveying: Cooling and air-conditioning system, boiler water supply and condensing system, machine-associated purpose, acids and alkali.
- Water treatment: Ultrafiltration system, reverse osmosis system, distillation system, separator, swimming pool.
- Irrigation: Farmland irrigation, spray irrigation, dripping irrigation.

● Operation conditions

- Thin, clean, non-flammable and non-explosive liquid containing no solid granules and fibers.
- Liquid temperature:
Normal temperature type: -15°C ~ +70°C,
Hot water type: -15°C ~ +120°C
- Ambient temperature: up to +40°C
- Altitude: up to 1000m

CDL/CDF200

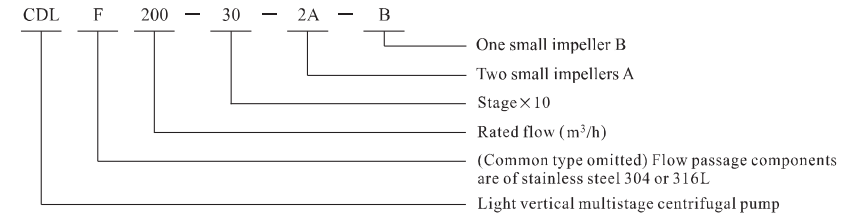

● Max working pressure

Model	Max. pressure(bar)
CDL1,2,3,4,5 Flange	25
CDL(F)1,2,3,4,5 Over Flange	16
CDF1,2,3,4,5 Flange, cutting ferrule joint, pipe thread	25
CDL8,10,12,15,16,20 Flange	25
CDL(F)8 Oval Flange	16
CDF8,10,12,15,16,20 Flange, cutting ferrule joint, pipe thread	25
CDL32	
32-10-1 ~ 32-60-2	16(30)
32-60 ~ 32-100-2	30
CDF32	30
CDL42	
42-10-1 ~ 42-40-2	16(30)
42-40 ~ 42-60	25(30)
42-70-2 ~ 42-70	30
CDF42	
42-10-1 ~ 42-60	25(30)
42-70-2 ~ 42-70	30
CDL65	
65-10-1 ~ 65-30	16(25)
65-40-2 ~ 65-50-2	25
CDL85	
85-10-1 ~ 85-30-2	16(25)
85-30-1 ~ 85-40-2	25
CDF65,85	25
CDL, CDF120, 150, 200	20

Pumps with pressure inside brackets need to specify especially.

● Max. Ambient temperature

When the pump operates under ambient temperature higher than 40°C or under altitude higher than 1000m, because of low air density and poor cooling effects, the motor output power P2 will be decreased to certain extent. If the pump is operated under the above-said conditions, it should be equipped with motor of higher power.

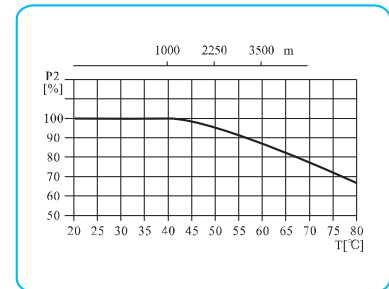

Curve illustration

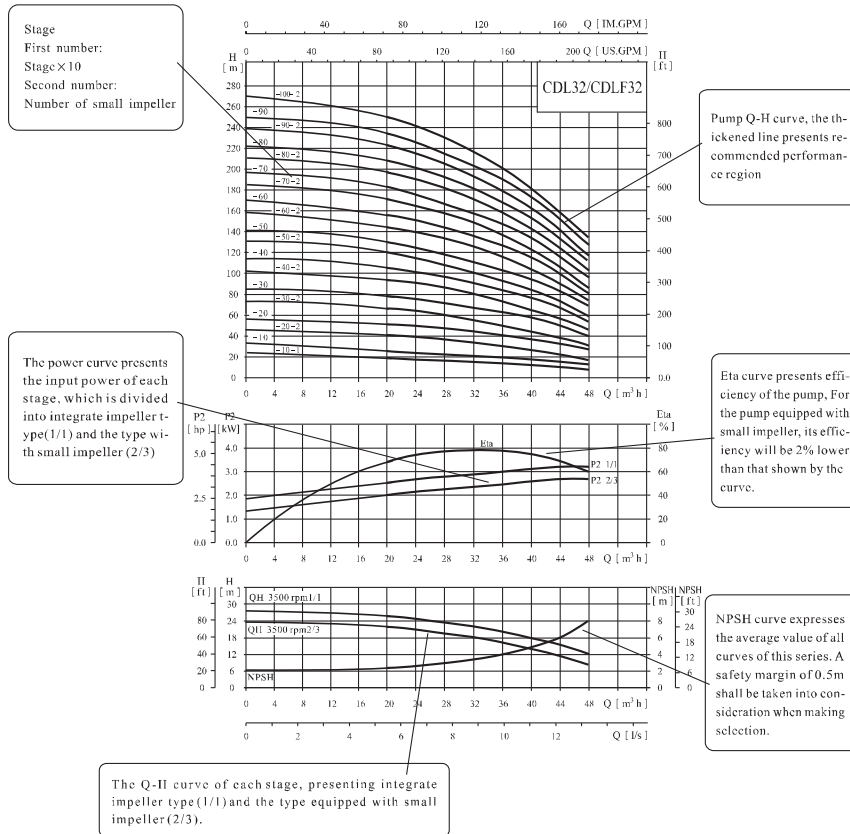

Performance curve

Following conditions are suitable for the performance curves shown below:

- 1、 All curves are based on the measured values of 60Hz: constant motor speed 3500 rpm or 3540rpm.
- 2、 Curve tolerance in conformity with ISO9906 Annex A.
- 3、 Measurement is done with 20°C air-free water, kinematic viscosity of 1mm²/sec.

- 4、 The operation of pump shall refer to the performance region indicated by the thickened curve to prevent overheating due to too small flow rate or overload of motor due to too large flow rate.

Minimum inlet pressure NPSH

In case that the pressure in pump is lower than the steam pressure used to convey liquid, the cavitations will occur. To avoid cavitations, a minimum pressure at the inlet side of the pump shall be guaranteed. The maximum suction stroke can be calculated with following formula:

$$H = P_b \times 10.2 - NPSH - H_f - H_v - H_s$$

P_b = atmosphere pressure [bar]
(can be set as 1bar)

In a closed system, P_b means system pressure [bar]

$NPSH$ = Net positive suction head [m]

(It can be read out from the point of possible max. flow rate shown on NPSH curve)

H_f = Pipeline loss at the inlet [m]

H_v = Steam pressure [m]

H_s = Safety margin = Minimum 0.5m delivery head

If the calculated result H is positive, the pump may run under the max. Suction stroke H.

In case the calculated result H is negative, a delivery head of min. Inlet pressure is necessary.

Operation in parallel

Connecting several pumps in parallel running will benefit much more than running a single large pump.

- Applicable to different working states necessary in a variable flow system.
- Increasing the possibility of water supply when the pump is in failure. Because in case of pump failure, only part of the system flow is effected.

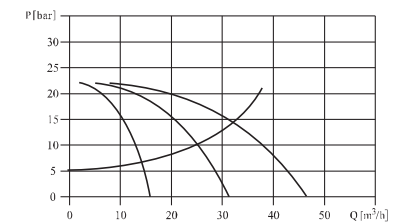

Two pumps or more can be connected in parallel running if necessary.

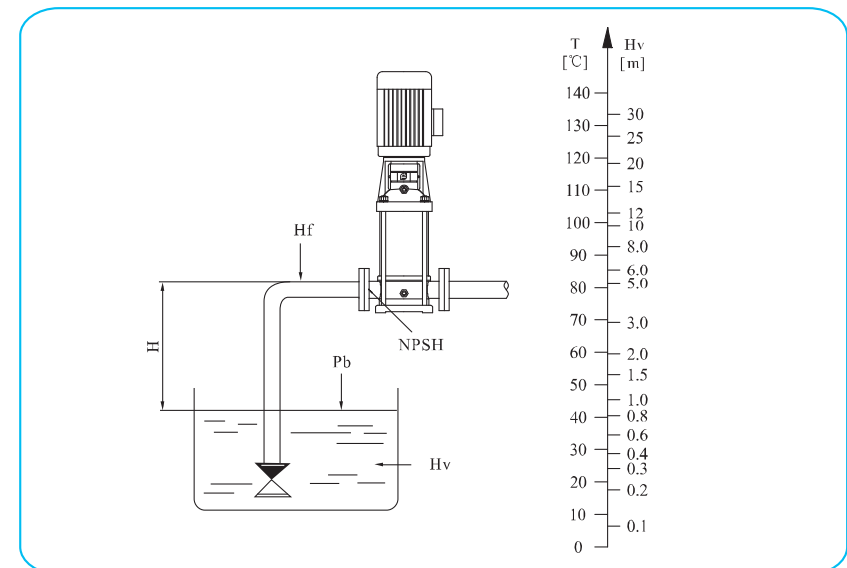

Check and ensure that the pump is not at cavitations state.

● Section drawing CDL/CDLF1,2,3,4,5

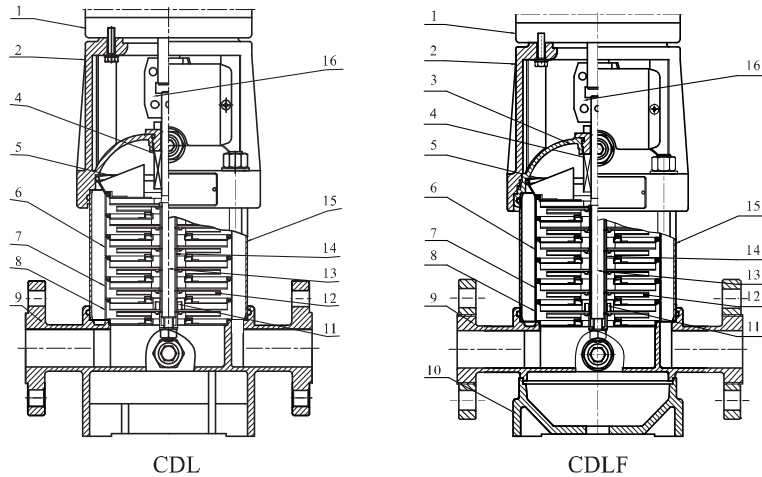

● Section drawing CDL/CDLF8,10,12,15,16,20

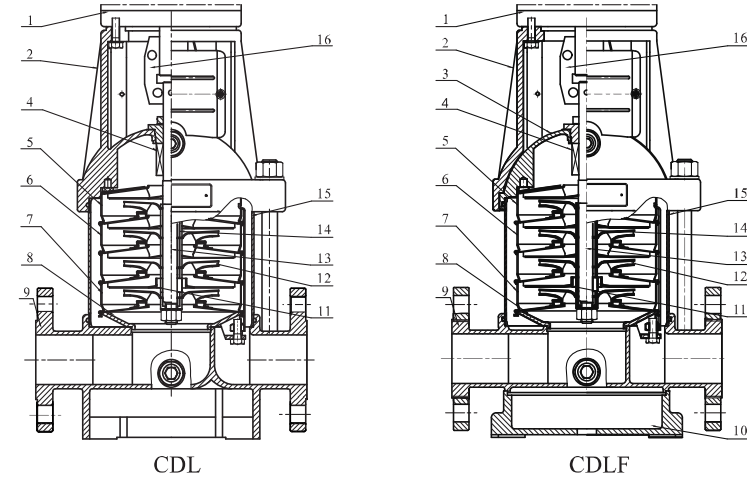

● Material CDL/CDLF1,2,3,4,5

NO.	Name	Material	AISI/ASTM
1	Motor		
2	Pump head	Cast iron	ASTM25B
4	Mechanical seal		
5	Top diffuser	Stainless steel	AISI304
6	Diffuser	Stainless steel	AISI304
7	Support diffuser	Stainless steel	AISI304
8	Inducer	Stainless steel	AISI304
11	Bearing	Tungsten carbide	
12	Impeller	Stainless steel	AISI304
13	Shaft	Stainless steel	AISI304 AISI316L

NO.	Name	Material	AISI/ASTM
14	Impeller sleeve	Stainless steel	AISI304
15	Cylinder	Stainless steel	AISI304
16	Coupling	Carbon steel	
CDLF			
3	Seal base	Stainless steel	AISI304
9	Inlet and outlet chamber	Stainless steel	AISI304
10	Base plate	Cast iron	ASTM25B
CDL			
9	Inlet and outlet chamber	Cast iron	ASTM25B

● Material CDL/CDLF8,10,12,15,16,20

NO.	Name	Material	AISI/ASTM
1	Motor		
2	Pump head	Cast iron	ASTM25B
4	Mechanical seal		
5	Top diffuser	Stainless steel	AISI304
6	Diffuser	Stainless steel	AISI304
7	Support diffuser	Stainless steel	AISI304
8	Inducer	Stainless steel	AISI304
11	Bearing	Tungsten carbide	
12	Impeller	Stainless steel	AISI304
13	Shaft	Stainless steel	AISI304 AISI316L

NO.	Name	Material	AISI/ASTM
14	Impeller sleeve	Stainless steel	AISI304
15	Cylinder	Stainless steel	AISI304
16	Coupling	Carbon steel	
CDLF			
3	Seal base	Stainless steel	AISI304
9	Inlet and outlet chamber	Stainless steel	AISI304
10	Base plate	Cast iron	ASTM25B
CDL			
9	Inlet and outlet chamber	Cast iron	ASTM25B

● Section drawing CDL/CDLF32,42,65,85

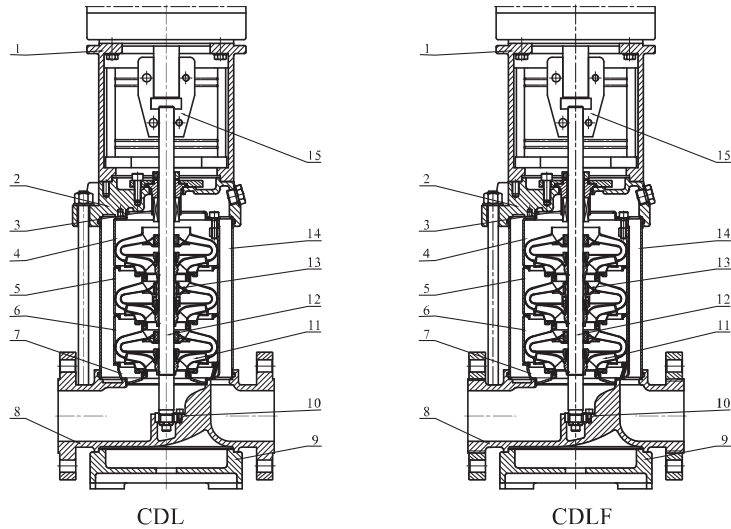

● Material CDL/CDLF32,42,65,85

NO.	Name	Material	AISI/ASTM
1	Bracket	Cast iron	ASTM25B
3	Mechanical seal		
4	Top diffuser	Stainless steel	AISI304
5	Support diffuser	Stainless steel	AISI304
6	Diffuser	Stainless steel	AISI304
7	Inducer	Stainless steel	AISI304
9	Base plate	Cast iron	ASTM25B
10	Bottom bearing	Tungsten carbide	
11	Impeller	Stainless steel	AISI304

NO.	Name	Material	AISI/ASTM
12	Shaft	Stainless steel	AISI316L AISI304 AISI431
13	Intermediate bearing	Tungsten carbide	
14	Cylinder	Stainless steel	AISI304
15	Coupling	Carbon steel	
	Rubber parts	NBR	
CDL			
2	Pump head	Cast iron	ASTM25B
8	Inlet and outlet chamber	Cast iron	ASTM25B
CDLF			
2	Pump head	Stainless steel	AISI304
8	Inlet and outlet chamber	Stainless steel	AISI304

● Section drawing CDL/CDLF120,150,200

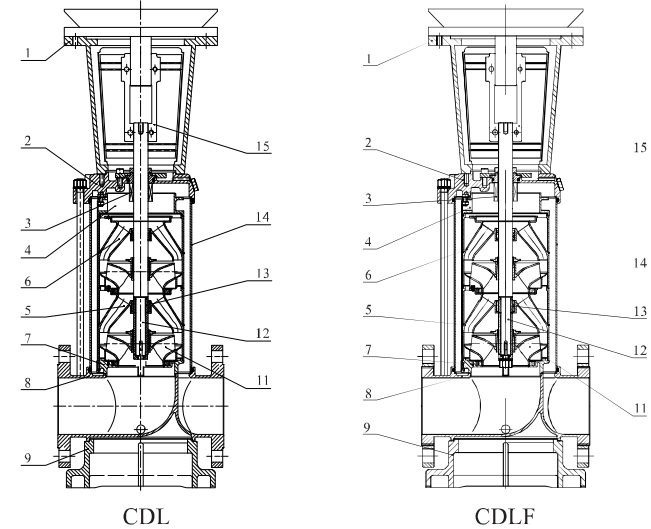

● Material CDL/CDLF120,150,200

NO.	Name	Material	AISI/ASTM
1	Bracket	Cast iron	ASTM25B
3	Mechanical seal		
4	Discharge	Stainless steel	AISI304
5	Support diffuser	Stainless steel	AISI304
6	Diffuser	Stainless steel	AISI304
7	Inducer	Stainless steel	AISI304
9	Base plate	Cast iron	ASTM 80-55-06
11	Impeller	Stainless steel	AISI304
12	Shaft	Stainless steel	AISI304

NO.	Name	Material	AISI/ASTM
13	Bearing	Tungsten carbide	
14	Cylinder	Stainless steel	AISI304
15	Coupling	Carbon steel	
	Rubber parts	NBR	
CDL			
2	Pump head	Cast iron	ASTM 80-55-06
8	Inlet and outlet chamber	Cast iron	ASTM 80-55-06
CDLF			
2	Pump head	Stainless steel	AISI304
8	Inlet and outlet chamber	Stainless steel	AISI304

● Performance curve

ISO9906 Annex A 3500rpm

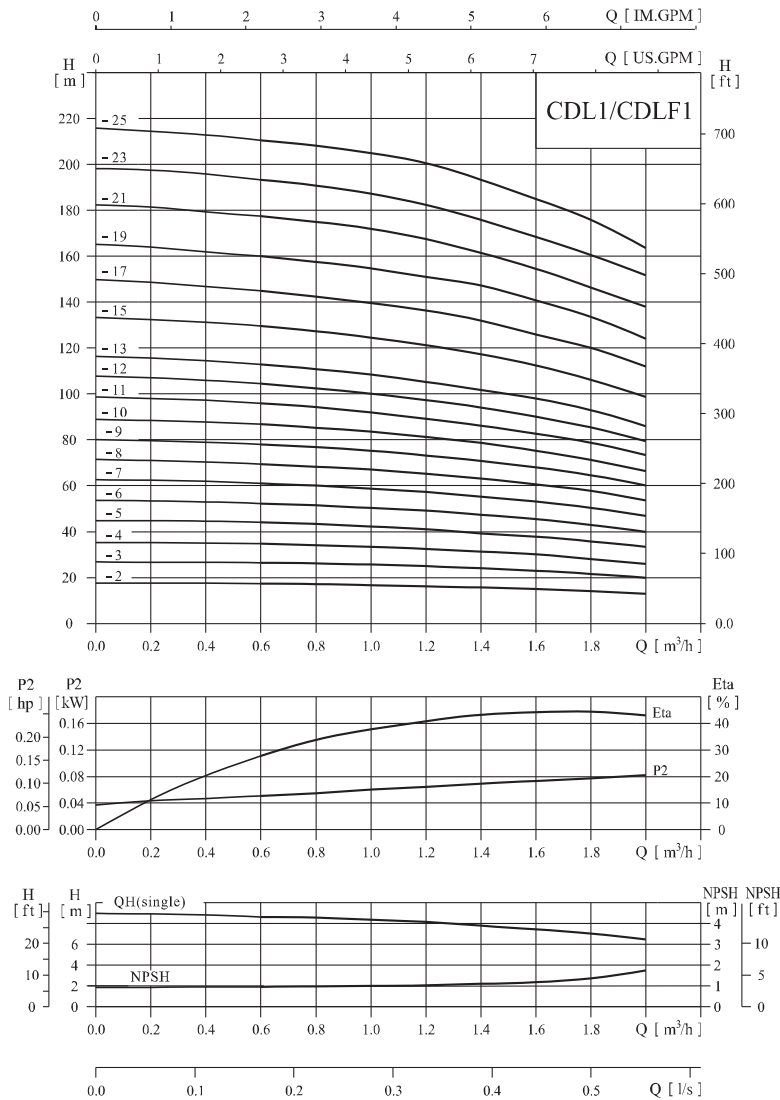

● Performance table

Model	Driving motor		Q (m³/h)	0.6	0.8	1	1.2	1.4	1.6	1.8	2
	(kW)	(hp)									
CDL1-2	0.37	0.5		17.5	17	16.5	16	15.5	15	14	13
CDL1-3	0.37	0.5		26.5	26	25	24	23	22	21	20
CDL1-4	0.37	0.5		35	34	33	32	31	30	28	26
CDL1-5	0.55	0.75		43	42	41	40	39	38	35	33
CDL1-6	0.55	0.75		52	51	50	48	47	45	43	39
CDL1-7	0.75	1		60	59	58	56	55	52	50	46
CDL1-8	0.75	1		68	67	65	64	62	59	57	53
CDL1-9	0.75	1		76	75	74	73	71	66	64	60
CDL1-10	1.1	1.5		85	84	83	81	78	74	72	67
CDL1-11	1.1	1.5		95	93	90	87	85	81	78	73
CDL1-12	1.1	1.5		103	102	98	96	92	88	86	79
CDL1-13	1.1	1.5		112	110	107	105	100	95	93	86
CDL1-15	1.5	2		127	125	123	121	117	112	107	99
CDL1-17	1.5	2		144	141	139	137	132	124	120	112
CDL1-19	2.2	3		160	157	155	153	147	141	134	124
CDL1-21	2.2	3		177	174	172	168	162	153	147	138
CDL1-23	2.2	3		193	190	188	184	174	167	161	152
CDL1-25	3	4		210	207	205	202	192	184	176	164

● Installation sketch

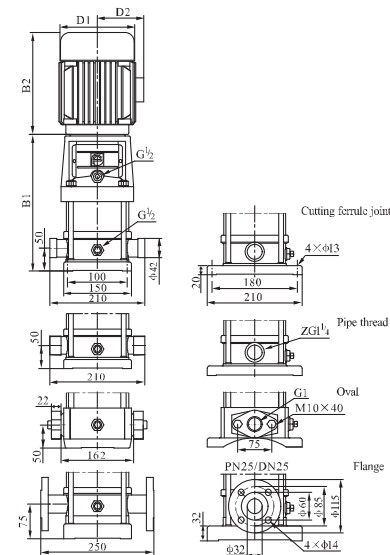

● Size and weight

Model	Size (mm)					Weight (kg)
	B1	B2	B1+B2	D1	D2	
CDL1-2	258	225	483	148	117	20
CDL1-3	276	225	501	148	117	20
CDL1-4	294	225	519	148	117	21
CDL1-5	312	225	537	148	117	22
CDL1-6	330	225	555	148	117	23
CDL1-7	358	245	603	170	142	26
CDL1-8	376	245	621	170	142	27
CDL1-9	394	245	639	170	142	28
CDL1-10	412	245	657	170	142	29
CDL1-11	430	245	675	170	142	29
CDL1-12	448	245	693	170	142	30
CDL1-13	466	245	711	170	142	31
CDL1-15	512	290	802	190	155	37
CDL1-17	548	290	838	190	155	38
CDL1-19	584	290	874	190	155	41
CDL1-21	620	290	910	190	155	42
CDL1-23	656	290	946	190	155	43
CDL1-25	702	345	1047	197	165	51

CDL1-19 - 1-25 sub-connection of pipeline has no oval flange connection.
The overall dimensions of the single-phase motor and explosion-proof motor are a little different. Pls contact us for details.

● Performance curve

ISO9906 Annex A 3500rpm

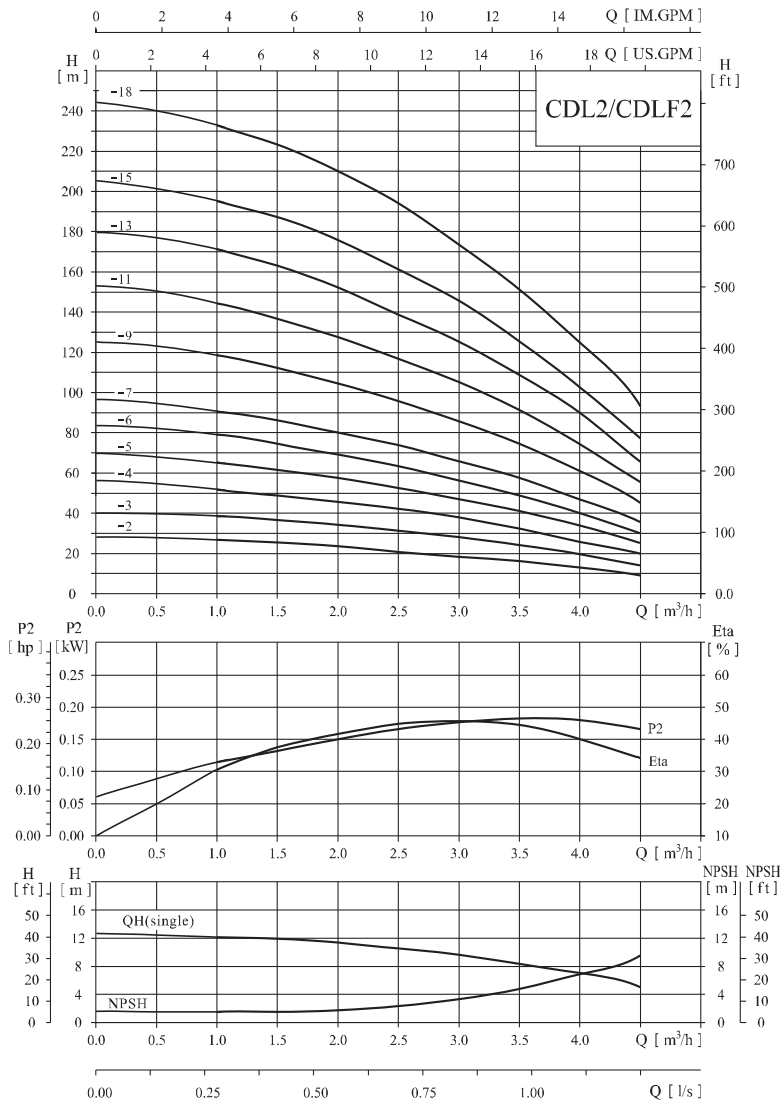

● Performance table

Model	Driving motor		Q (m³/h)	H (m)								
	(kW)	(hp)		1	1.5	2	2.5	3	3.5	4	4.5	
CDL2-2	0.55	0.75		26	24	22	21	18	16	12	9	
CDL2-3	0.75	1		39	36	33	31	27	24	19	15	
CDL2-4	1.1	1.5		52	48	45	42	36	32	26	20	
CDL2-5	1.1	1.5		65	60	57	52	46	41	32	25	
CDL2-6	1.1	1.5		78	74	69	63	56	49	40	30	
CDL2-7	1.5	2		91	86	81	74	66	57	47	35	
CDL2-9	2.2	3		117	111	104	95	86	75	61	45	
CDL2-11	2.2	3		143	136	128	116	104	90	75	56	
CDL2-13	3	4		171	163	152	139	126	108	90	66	
CDL2-15	3	4		195	186	176	160	142	125	103	77	
CDL2-18	4	5.5		234	228	212	195	171	151	126	94	

● Installation sketch

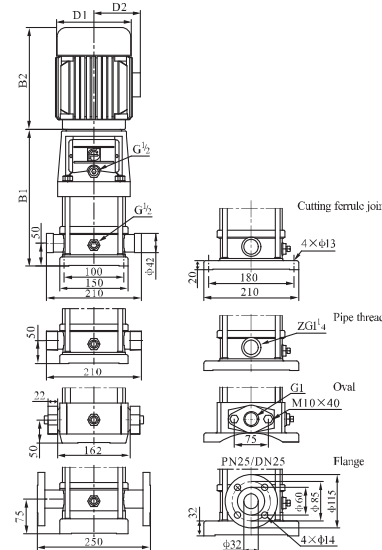

● Size and weight

Model	Size (mm)					Weight (kg)
	B1	B2	B1+B2	D1	D2	
CDL2-2	258	225	483	148	117	21
CDL2-3	286	245	531	170	142	24
CDL2-4	304	245	549	170	142	25
CDL2-5	322	245	567	170	142	26
CDL2-6	340	245	585	170	142	26
CDL2-7	368	290	658	190	155	32
CDL2-9	404	290	694	190	155	36
CDL2-11	440	290	730	190	155	37
CDL2-13	486	345	831	197	165	44
CDL2-15	522	345	867	197	165	45
CDL2-18	576	355	931	230	188	54

CDL2-13 ~ 2-18 sub-connection of pipeline has no oval flange connection. The overall dimensions of the single-phase motor and explosion-proof motor are a little different. Pls contact us for details.

Performance curve

ISO9906 Annex A 3500rpm

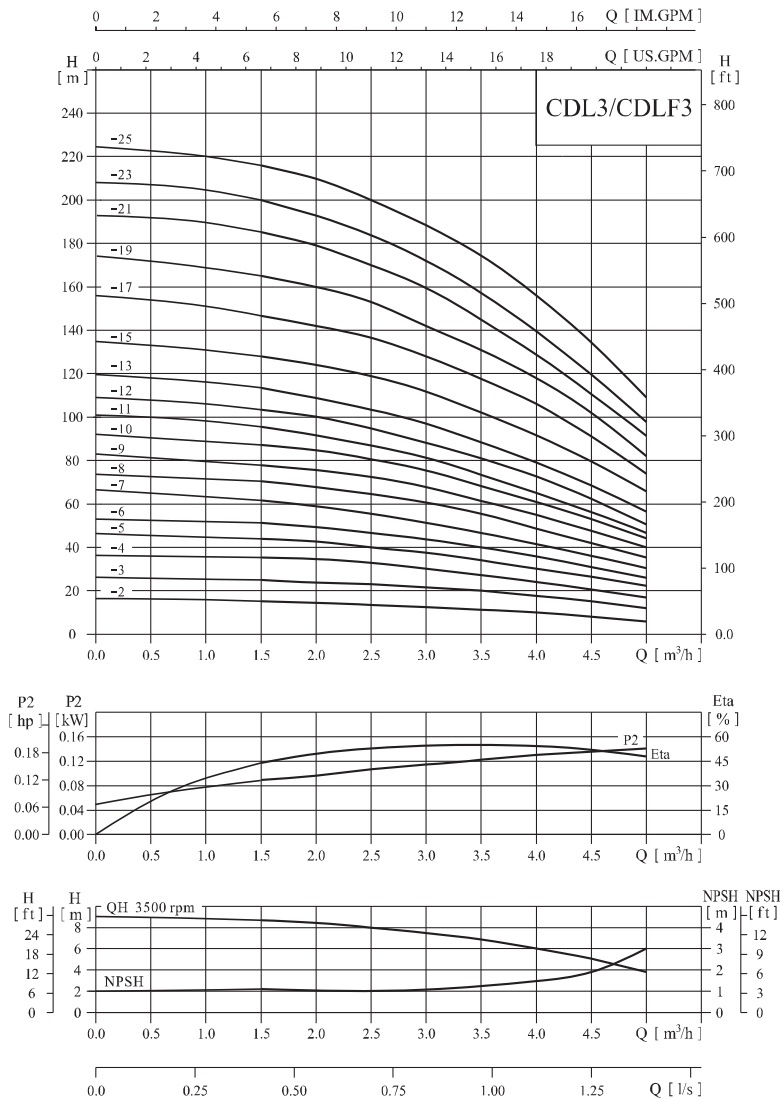

Performance table

Model	Driving motor		Q (m³/h)	1.5	2	2.5	3	3.5	4	4.5	5
	(kW)	(hp)									
CDL3-2	0.37	0.5		17.5	16	15	14	13	11	9	8
CDL3-3	0.55	0.75		26.5	25	24	23	20	18	15	12
CDL3-4	0.55	0.75		35	34	32	30	27	25	20	17
CDL3-5	0.75	1		44	42	40	38	33	31	26	23
CDL3-6	1.1	1.5		51	50	48	45	40	37	32	27
CDL3-7	1.1	1.5		61	59	56	52	46	43	38	31
CDL3-8	1.1	1.5		70	67	64	61	53	49	44	35
CDL3-9	1.5	2		78	77	72	68	60	56	50	40
CDL3-10	1.5	2		87	84	81	76	68	63	55	44
CDL3-11	1.5	2		96	92	87	82	74	69	59	48
CDL3-12	2.2	3		104	100	96	90	79	73	63	52
CDL3-13	2.2	3		112	109	104	98	86	80	69	57
CDL3-15	2.2	3		129	126	120	112	99	93	81	65
CDL3-17	2.2	3		147	143	137	128	114	106	91	74
CDL3-19	3	4		165	160	153	142	126	118	102	82
CDL3-21	3	4		183	178	170	160	141	129	112	91
CDL3-23	3	4		200	194	185	174	154	142	122	98
CDL3-25	4	5.5		217	211	202	187	167	154	134	108

Installation sketch

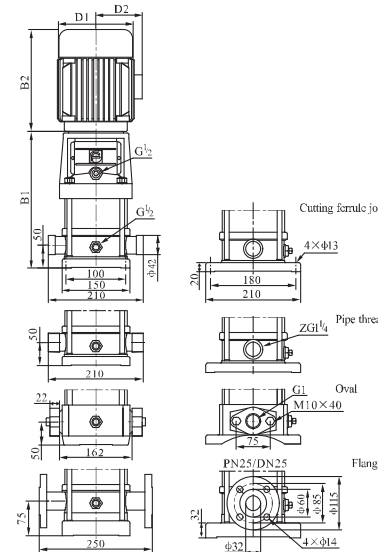

Size and weight

Model	Size (mm)					Weight (kg)
	B1	B2	B1+B2	D1	D2	
CDL3-2	258	225	483	148	117	20
CDL3-3	276	225	501	148	117	21
CDL3-4	294	225	519	148	117	22
CDL3-5	322	245	567	170	142	25
CDL3-6	340	245	585	170	142	26
CDL3-7	358	245	603	170	142	27
CDL3-8	376	245	621	170	142	27
CDL3-9	404	290	694	190	155	33
CDL3-10	422	290	712	190	155	34
CDL3-11	440	290	730	190	155	34
CDL3-12	458	290	748	190	155	37
CDL3-13	476	290	766	190	155	38
CDL3-15	512	290	802	190	155	39
CDL3-17	548	290	838	190	155	40
CDL3-19	594	345	939	197	165	48
CDL3-21	630	345	975	197	165	49
CDL3-23	666	345	1011	197	165	50
CDL3-25	702	355	1057	230	188	58

CDL3-17 ~ 3-25 sub-connection of pipeline has no oval flange connection. The overall dimensions of the single-phase motor and explosion-proof motor are a little different. Pls contact us for details.

● Performance curve

ISO9906 Annex A 3500rpm

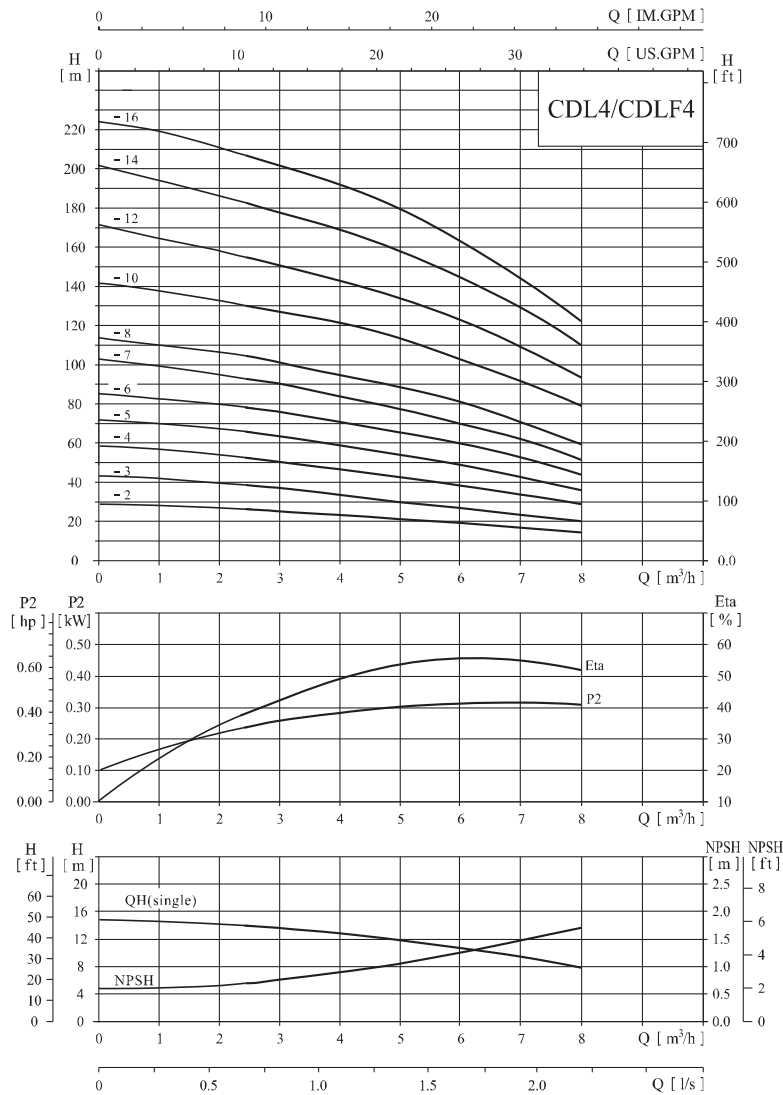

● Performance table

Model	Driving motor		Q (m³/h)	2.5	3	4	5	6	7	8
	(kW)	(hp)								
CDL4-2	0.75	1	H (m)	26	25	23	21	19	16	14
CDL4-3	1.1	1.5		39	38	36	32	28	24	21
CDL4-4	1.5	2		52	50	48	44	38	35	31
CDL4-5	2.2	3		65	62	60	55	49	44	39
CDL4-6	2.2	3		78	75	72	67	59	54	47
CDL4-7	3	4		92	88	84	78	69	62	55
CDL4-8	3	4		104	100	95	90	79	72	63
CDL4-10	4	5.5		130	125	120	113	102	90	80
CDL4-12	4	5.5		156	150	145	136	122	109	96
CDL4-14	5.5	7.5		182	176	170	159	145	129	112
CDL4-16	5.5	7.5		207	201	196	183	165	146	128

● Installation sketch

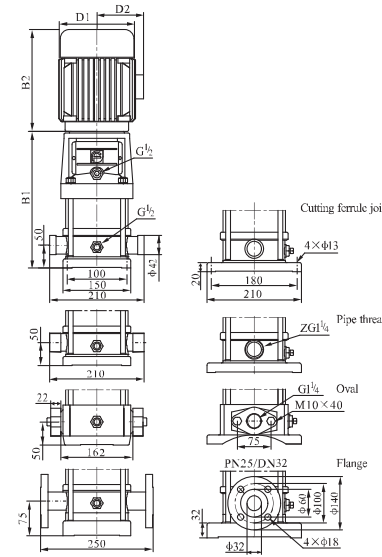

● Size and weight

Model	Size (mm)					Weight (kg)
	B1	B2	B1+B2	D1	D2	
CDL4-2	286	245	531	170	142	24
CDL4-3	313	245	558	170	142	25
CDL4-4	350	290	640	190	155	31
CDL4-5	376	290	667	190	155	34
CDL4-6	404	290	694	190	155	35
CDL4-7	441	345	786	197	165	42
CDL4-8	468	345	813	197	165	42
CDL4-10	522	355	877	230	188	51
CDL4-12	576	355	931	230	188	52
CDL4-14	650	390	1040	260	208	64
CDL4-16	704	390	1094	260	208	66

CDL4-12 ~ 4-16 sub-connection of pipeline has no oval flange connection. The overall dimensions of the single-phase motor and explosion-proof motor are a little different. Pls contact us for details.

Performance curve

ISO9906 Annex A 3500rpm

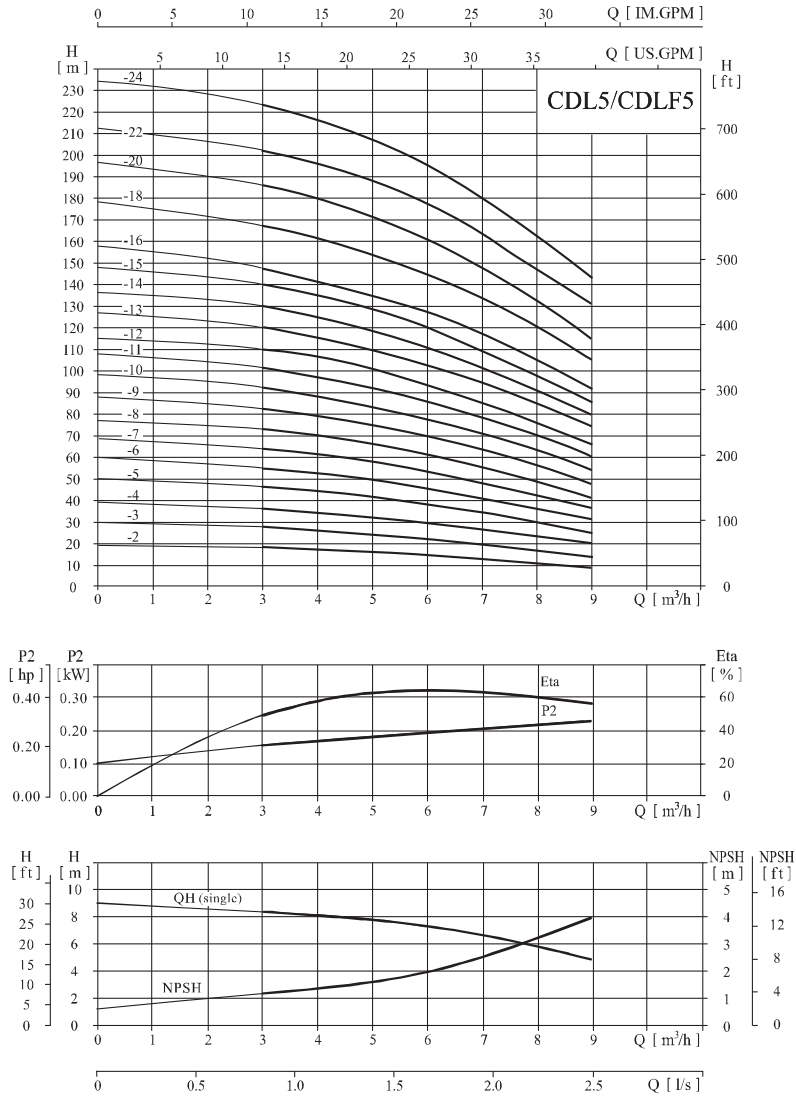

Performance table

Model	Driving motor		Q (m³/h)	3	4	5	6	7	8	9
	(kW)	(hp)								
CDL5-2	0.55	0.75	18	17	16	15	13	11	9	
CDL5-3	1.1	1.5	27	26	24	22	21	17	14	
CDL5-4	1.1	1.5	37	35	32	30	27	23	20	
CDL5-5	1.5	2	46	44	41	38	35	30	25	
CDL5-6	2.2	3	55	52	49	46	41	37	31	
CDL5-7	2.2	3	64	61	58	54	48	43	37	
CDL5-8	2.2	3	73	70	67	62	56	49	42	
CDL5-9	2.2	3	82	79	75	70	64	56	48	
CDL5-10	3	4	92	88	84	78	72	63	54	
CDL5-11	3	4	101	97	92	86	78	70	60	
CDL5-12	3	4	110	106	101	94	86	77	66	
CDL5-13	4	5.5	120	115	109	103	95	84	72	
CDL5-14	4	5.5	130	124	118	111	102	91	78	
CDL5-15	4	5.5	139	133	127	119	108	98	85	
CDL5-16	4	5.5	148	142	135	127	117	105	91	
CDL5-18	5.5	7.5	167	161	153	144	134	119	104	
CDL5-20	5.5	7.5	186	180	171	162	147	133	116	
CDL5-22	5.5	7.5	205	198	189	179	163	147	129	
CDL5-24	7.5	10	224	216	207	195	180	162	142	

Installation sketch

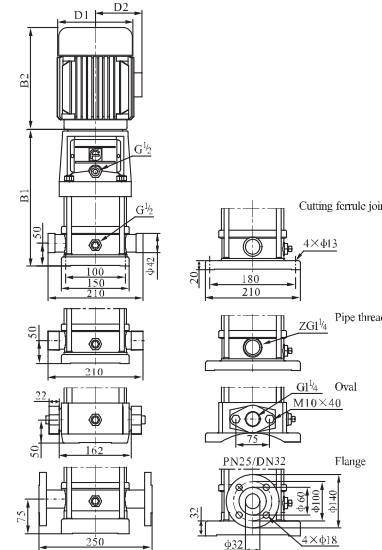

Size and weight

Model	Size (mm)					Weight (kg)
	B1	B2	B1+B2	D1	D2	
CDL5-2	276	225	501	148	117	27
CDL5-3	303	245	548	170	142	29
CDL5-4	330	245	575	170	142	29
CDL5-5	367	290	657	190	155	34
CDL5-6	394	290	684	190	155	37
CDL5-7	421	290	711	190	155	37
CDL5-8	448	290	738	190	155	38
CDL5-9	485	290	775	190	155	38
CDL5-10	512	345	857	197	165	47
CDL5-11	539	345	884	197	165	47
CDL5-12	566	345	911	197	165	48
CDL5-13	593	355	948	230	188	56
CDL5-14	620	355	975	230	188	57
CDL5-15	647	355	1002	230	188	57
CDL5-16	684	355	1039	230	188	58
CDL5-18	738	390	1128	260	208	76
CDL5-20	782	390	1172	260	208	77
CDL5-22	846	390	1236	260	208	78
CDL5-24	900	390	1290	260	208	82

CDL5-18-5-24 sub-connection of pipeline has no oval flange connection. The overall dimensions of the single-phase motor and explosion-proof motor are a little different. Pls contact us for details.

Performance curve

ISO9906 Annex A 3500rpm

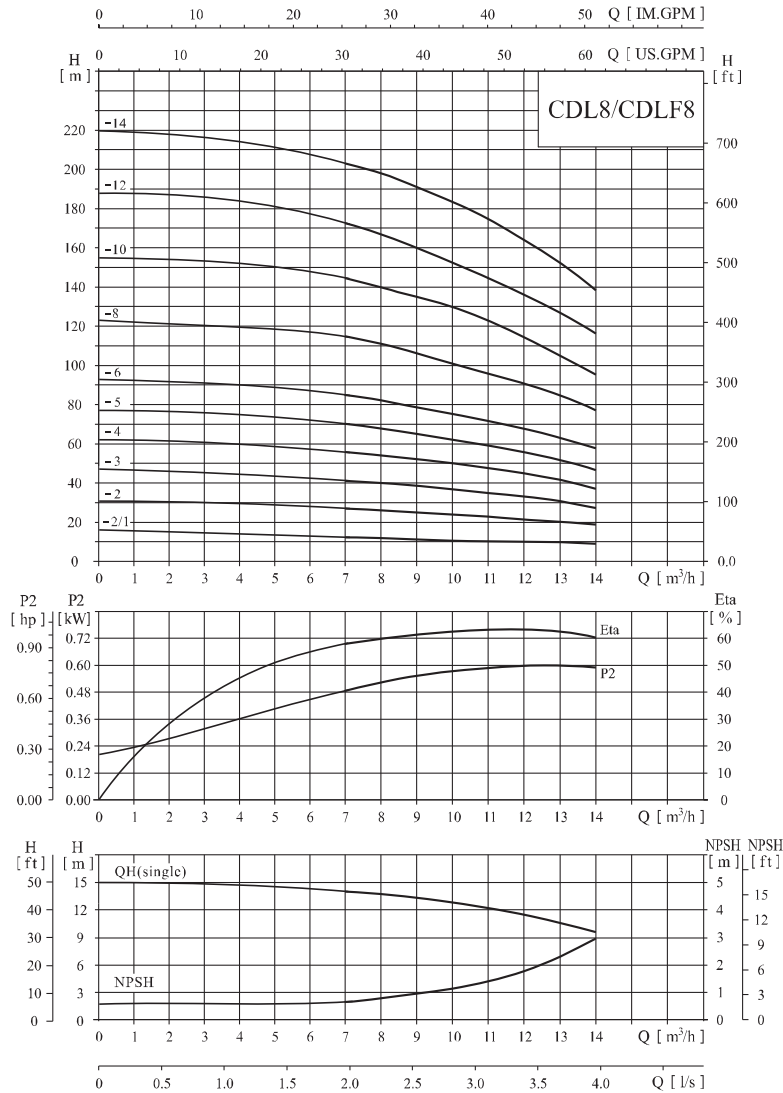

Performance table

Model	Driving motor		Q (m³/h)	7	8	9	10	11	12	13	14
	(kW)	(hp)		H (m)							
CDL8-2/1	0.75	1	7	13	12	11.5	11	10.5	10	9.5	9
CDL8-2	1.5	2	8	27	26	25	24	23	22	20	18
CDL8-3	2.2	3	9	41	40	38	37	35	33	30	28
CDL8-4	3	4	10	55	54	52	50	47	45	41	38
CDL8-5	3	4	11	70	68	65	63	59	56	52	47
CDL8-6	4	5.5	12	85	82	78	76	72	68	62	57
CDL8-8	5.5	7.5	13	115	110	105	101	97	91	84	75
CDL8-10	7.5	10	14	145	140	132	126	122	115	105	95
CDL8-12	7.5	10	15	173	167	160	152	147	132	125	115
CDL8-14	11	15	16	202	195	188	179	174	163	147	135

Installation sketch

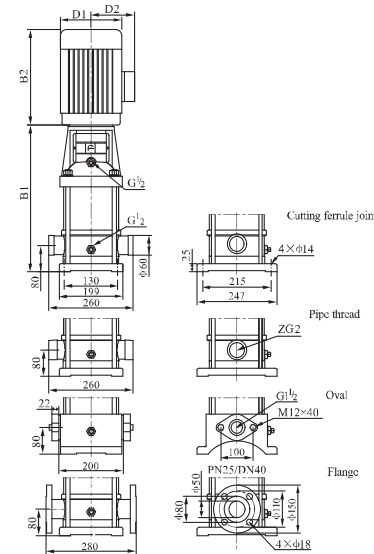

Size and weight

Model	Size (mm)					Weight (kg)
	B1	B2	B1+B2	D1	D2	
CDL8-2/1	347	245	592	170	142	32
CDL8-2	357	290	647	190	155	38
CDL8-3	387	290	677	190	155	41
CDL8-4	427	345	772	197	165	49
CDL8-5	457	345	802	197	165	50
CDL8-6	487	355	842	230	188	58
CDL8-8	567	390	957	260	208	71
CDL8-10	627	390	1017	260	208	80
CDL8-12	687	390	1077	260	208	82
CDL8-14	835	500	1335	330	255	153

CDL8-10 ~ 8-14 sub-connection of pipeline has no oval flange connection. The overall dimensions of the single-phase motor and explosion-proof motor are a little different. Pls contact us for details.

● Performance curve ISO9906 Annex A 3500rpm

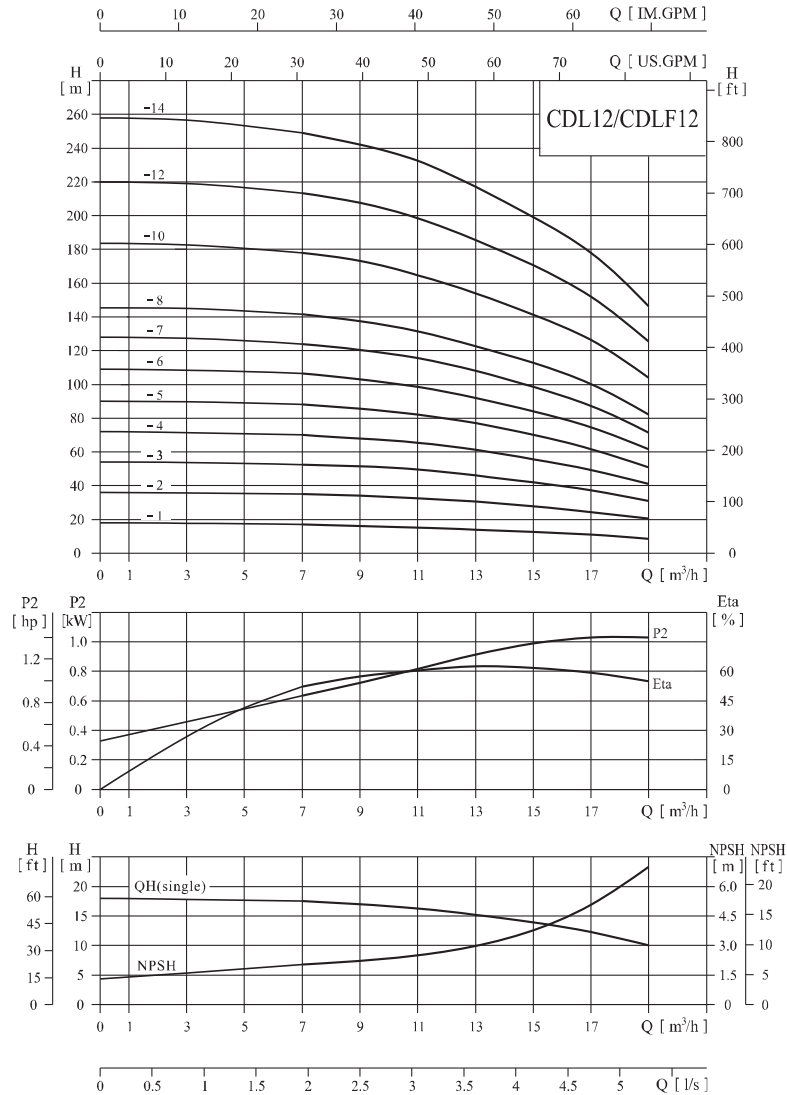

● Performance table

Model	Driving motor		Q (m³/h)	7	9	11	12	13	15	17	19
	(kW)	(hp)									
CDL12-1	1.1	1.5		17	16	15	14.5	14	12.5	11	8.5
CDL12-2	2.2	3		35	34	32.5	32	30.5	27	24.5	20.5
CDL12-3	4	5.5		52.5	51.5	50	48	46	41.5	37.5	31
CDL12-4	5.5	7.5		70	68	65.5	64	61.5	55	49.5	41
CDL12-5	5.5	7.5		88	86	82	80	77	70	62	51
CDL12-6	7.5	10		107	103	99	96	92	84	75	61
CDL12-7	7.5	10		124	121	116	112	107	97	88	71
CDL12-8	11	15		141	137	132	128	122	111	101	82
CDL12-10	11	15		178	173	166	161	153	140	128	104
CDL12-12	15	20		213	208	199	193	185	169	154	125
CDL12-14	15	20		249	242	233	225	216	198	180	145

● Installation sketch

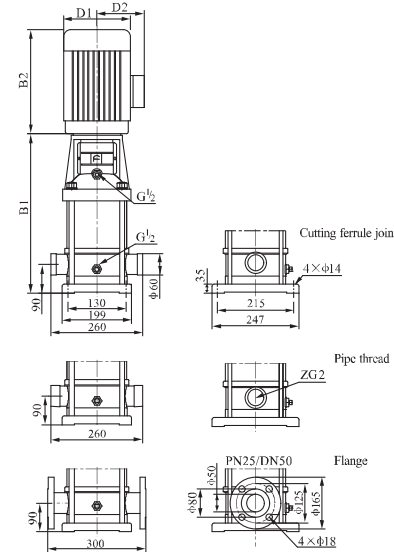

● Size and weight

Model	Size (mm)					Weight (kg)
	B1	B2	B1+B2	D1	D2	
CDL12-1	357	245	602	170	142	32
CDL12-2	367	290	657	190	155	41
CDL12-3	407	355	762	230	188	56
CDL12-4	457	390	847	260	208	69
CDL12-5	487	390	877	260	208	71
CDL12-6	517	390	907	260	208	77
CDL12-7	547	390	937	260	208	78
CDL12-8	665	500	1165	330	255	147
CDL12-10	725	500	1225	330	255	151
CDL12-12	785	500	1285	330	255	164
CDL12-14	845	500	1345	330	255	167

The overall dimensions of the single-phase motor and explosion-proof motor are a little different. Pls contact us for details.

● Performance curve ISO9906 Annex A 3500rpm

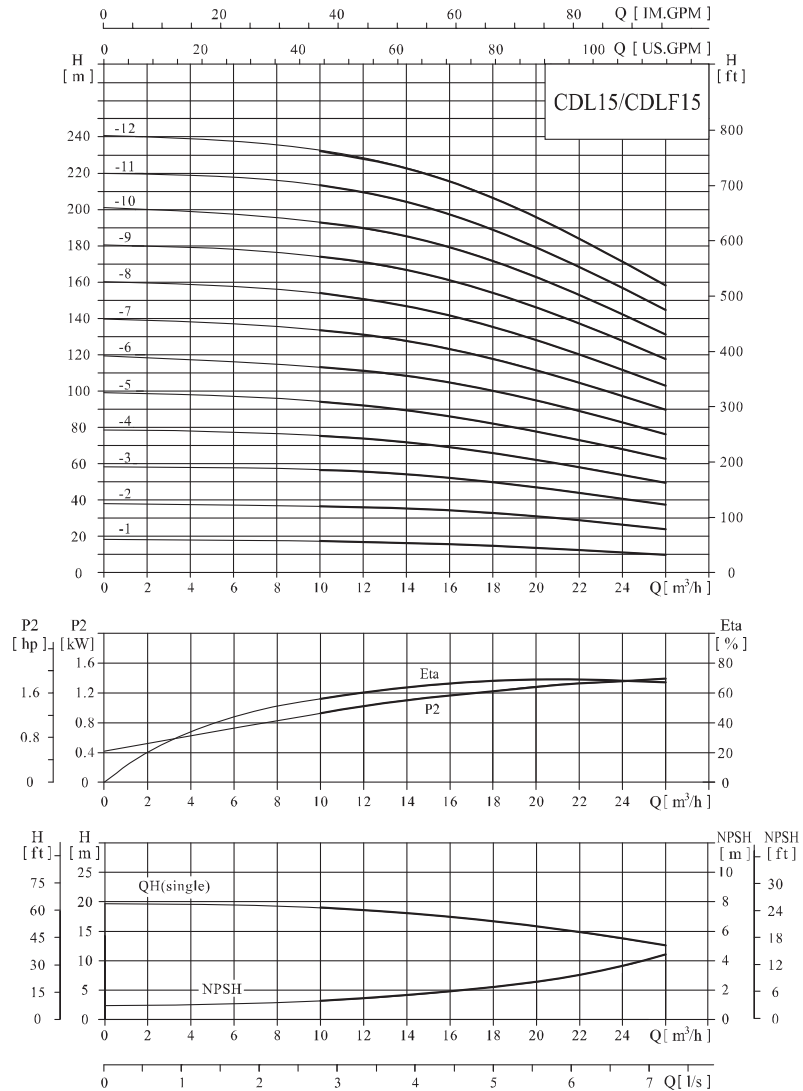

● Performance table

Model	Driving motor		Q (m³/h)	10	12	14	15	16	18	20	22	24	26
	(kW)	(hp)											
CDL15-1	1.5	2	H (m)	17.5	17	16.5	16	15.5	15	14	12.5	11	9.5
CDL15-2	3	4		36.5	36	35.5	35	34.5	33	31	29	27	24
CDL15-3	4	5.5		56	55	54	53	52	50	47	44	41	37
CDL15-4	5.5	7.5		75	74	72	71	69	66	62	58	54	49
CDL15-5	7.5	10		94	92	90	88	87	83	79	74	68	62
CDL15-6	11	15		113	111	108	107	105	101	95	89	83	76
CDL15-7	11	15		134	131	128	126	124	118	112	105	98	90
CDL15-8	11	15		154	151	147	144	142	136	129	121	112	103
CDL15-9	15	20		174	171	167	164	161	155	147	138	128	118
CDL15-10	15	20		193	190	186	182	180	172	163	154	143	131
CDL15-12	18.5	25		232	228	223	219	216	207	197	185	172	158

● Installation sketch

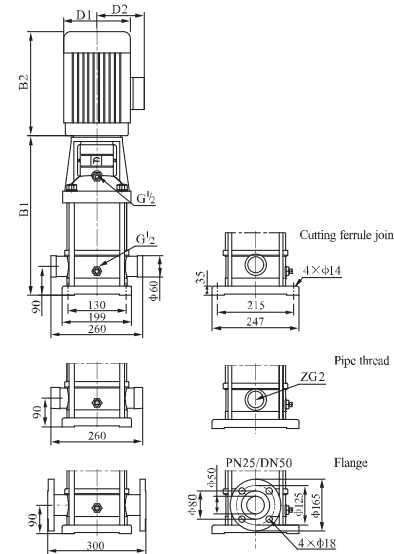

● Size and weight

Model	Size (mm)					Weight (kg)
	B1	B2	B1+B2	D1	D2	
CDL15-1	397	290	687	190	155	39
CDL15-2	407	345	752	197	165	49
CDL15-3	452	355	807	230	188	58
CDL15-4	517	390	907	260	208	71
CDL15-5	562	390	952	260	255	81
CDL15-6	695	500	1195	330	255	150
CDL15-7	740	500	1240	330	255	152
CDL15-8	785	500	1285	330	255	153
CDL15-9	830	500	1330	330	255	165
CDL15-10	875	500	1375	330	255	167
CDL15-12	965	550	1515	330	255	191

The overall dimension of the single-phase motor and explosion-proof motor are a little different. Pls contact us for details.

● Performance curve ISO9906 Annex A 3500rpm

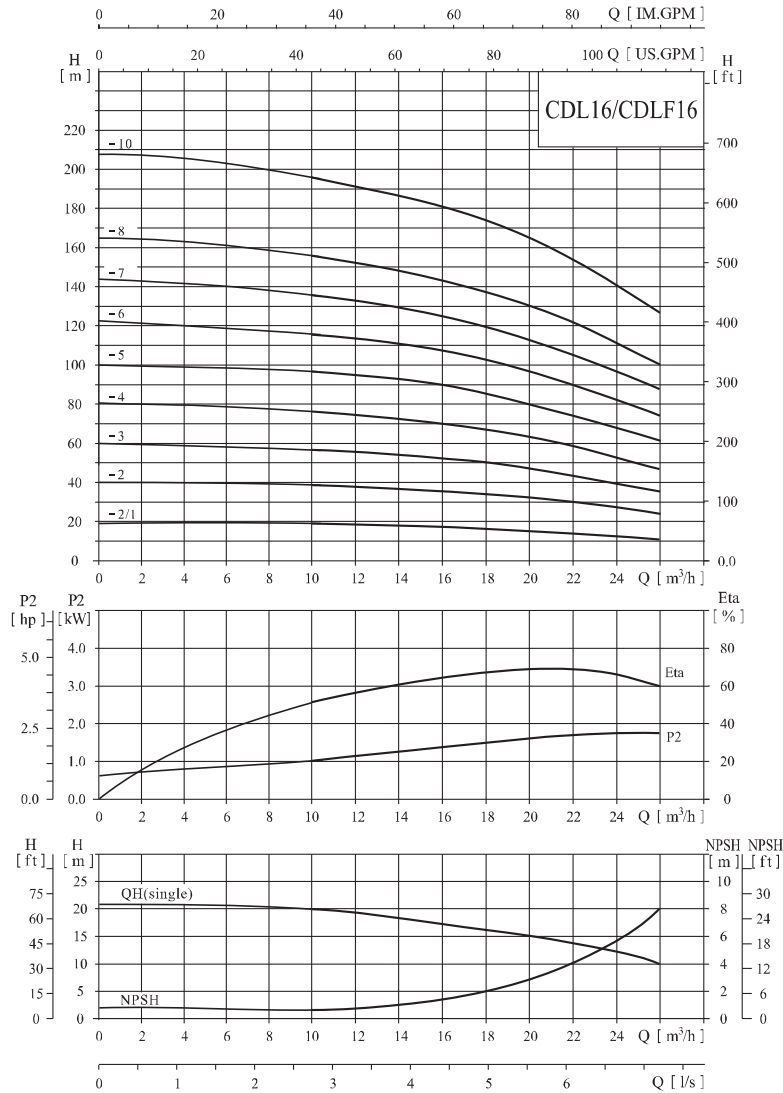

● Performance table

Model	Driving motor		Q (m³/h)	H (m)										
	(kW)	(hp)		10	12	14	16	18	20	22	24	26		
CDL16-2/1	2.2	3		19	18.5	18	17	16	15	14	13	11		
CDL16-2	4	5.5		38	37	36	35	34	32	30	27	24		
CDL16-3	5.5	7.5		57	56	55	54	51	48	45	40	36		
CDL16-4	7.5	10		76	75	73	72	68	64	60	54	49		
CDL16-5	11	15		96	94	92	90	85	80	75	68	62		
CDL16-6	11	15		115	113	111	108	102	96	91	82	75		
CDL16-7	15	20		135	132	129	126	119	113	106	96	88		
CDL16-8	15	20		155	152	148	144	137	130	122	111	101		
CDL16-10	18.5	25		197	192	187	181	174	165	153	139	127		

● Installation sketch

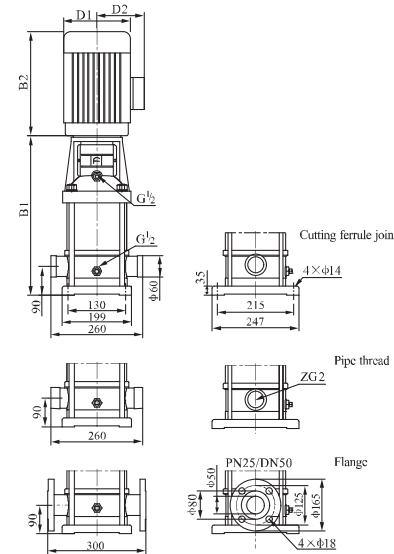

● Size and weight

Model	Size (mm)					Weight (kg)
	B1	B2	B1+B2	D1	D2	
CDL16-2/1	397	290	687	190	155	42
CDL16-2	407	355	762	230	188	56
CDL16-3	472	390	862	260	208	68
CDL16-4	517	390	907	260	208	75
CDL16-5	650	500	1150	330	255	148
CDL16-6	695	500	1195	330	255	150
CDL16-7	740	500	1240	330	255	161
CDL16-8	785	500	1285	330	255	163
CDL16-10	875	550	1425	330	255	186

The overall dimensions of the single-phase motor and explosion-proof motor are a little different. Pls contact us for details.

● Performance curve ISO9906 Annex A 3500rpm

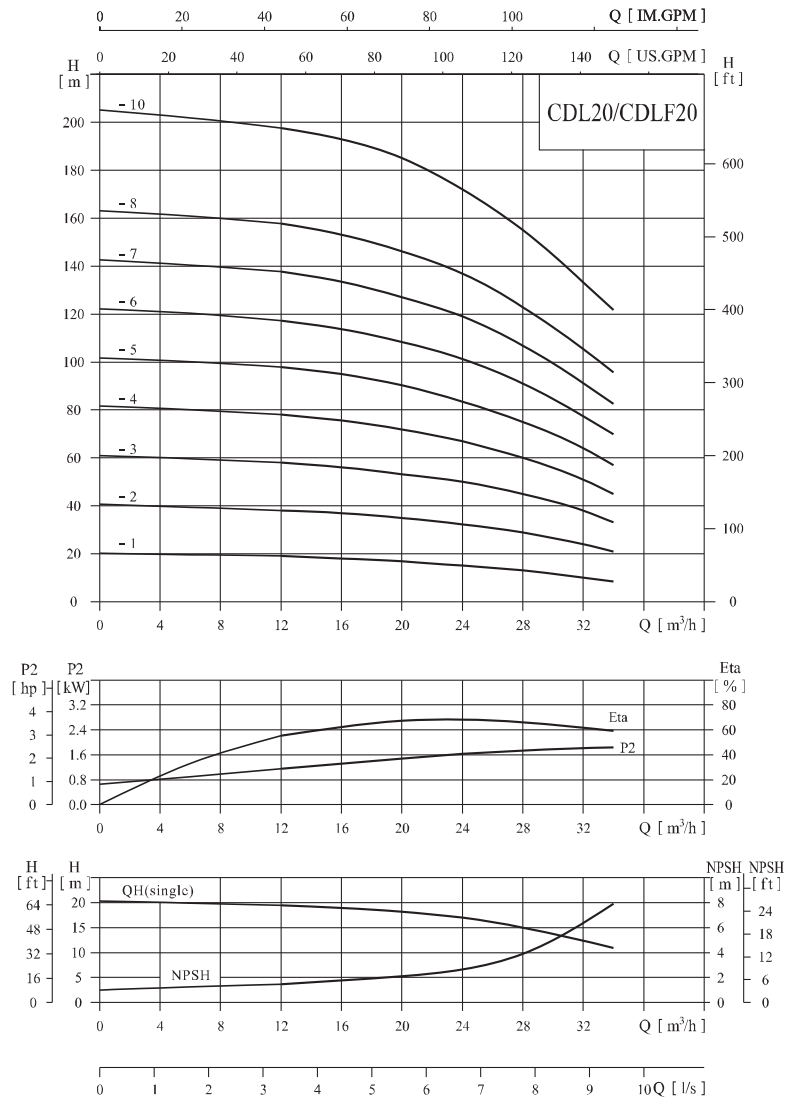

● Performance table

Model	Driving motor		Q (m³/h)	12	16	20	24	28	32	34
	(kW)	(hp)								
CDL20-1	2.2	3	H (m)	19	18	17	15	13	10	8.5
CDL20-2	4.0	5.5		38	37	35	32	29	24	21
CDL20-3	5.5	7.5		58	56	53	50	45	38	33
CDL20-4	7.5	10		78	75	72	67	60	51	45
CDL20-5	11	15		98	94	90	85	75	64	57
CDL20-6	11	15		118	113	108	102	91	77	70
CDL20-7	15	20		138	133	127	119	107	91	83
CDL20-8	15	20		158	153	146	137	123	105	96
CDL20-10	18.5	25		198	193	185	172	155	133	122

● Installation sketch

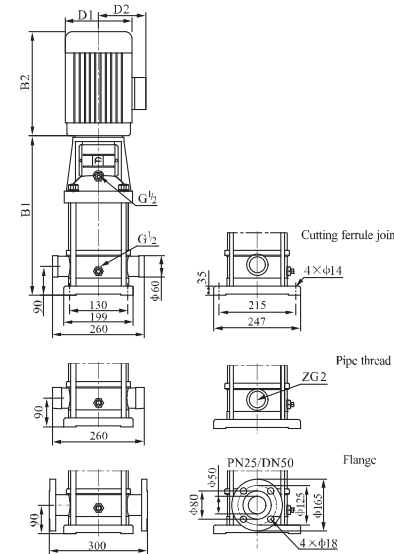

● Size and weight

Model	Size (mm)					Weight (kg)
	B1	B2	B1+B2	D1	D2	
CDL20-1	397	290	687	190	155	41
CDL20-2	407	355	762	230	188	56
CDL20-3	472	390	862	260	208	69
CDL20-4	517	390	907	260	208	79
CDL20-5	650	500	1150	330	255	148
CDL20-6	695	500	1195	330	255	150
CDL20-7	740	500	1240	330	255	162
CDL20-8	785	500	1285	330	255	163
CDL20-10	875	550	1425	330	255	187

The overall dimensions of the single-phase motor and explosion-proof motor are a little different. Pls contact us for details.

● Performance curve ISO9906 Annex A 3500rpm

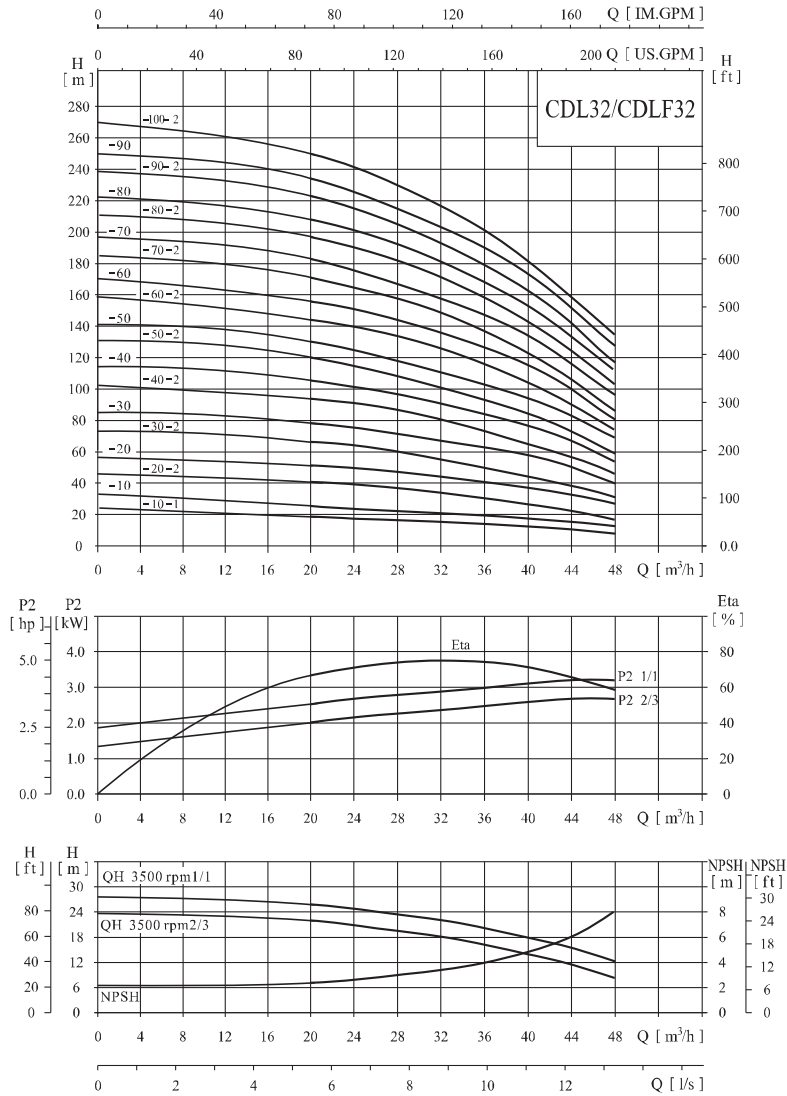

● Performance table

Model	Driving motor		Q (m³/h)	20	24	28	32	36	40	44	48
	(kW)	(hp)									
CDL32-10-1	3.0	4	20	19	18	17	15	13	10	7	
CDL32-10	4.0	5.5	26	25	24	23	21	19	17	14	
CDL32-20-2	5.5	7.5	41	40	38	35	31	27	22	17	
CDL32-20	7.5	10	52	50	48	45	41	37	33	27	
CDL32-30-2	7.5	10	67	64	61	57	52	46	39	31	
CDL32-30	11	15	78	75	71	67	62	56	50	40	
CDL32-40-2	11	15	94	91	87	81	73	65	56	45	
CDL32-40	15	20	104	101	96	91	83	75	66	55	
CDL32-50-2	15	20	119	115	109	102	94	84	73	59	
CDL32-50	18.5	25	130	125	119	112	104	94	83	69	
CDL32-60-2	18.5	25	145	140	134	126	116	104	90	74	
CDL32-60	18.5	25	155	150	144	136	126	114	100	81	
CDL32-70-2	22	30	172	166	158	149	137	123	106	86	
CDL32-70	22	30	182	176	168	159	148	133	118	97	
CDL32-80-2	22	30	196	190	182	172	159	143	124	102	
CDL32-80	30	40	208	201	192	181	167	152	132	111	
CDL32-90-2	30	40	223	216	206	194	179	162	142	117	
CDL32-90	30	40	234	226	216	204	189	172	152	127	
CDL32-100-2	30	40	248	241	231	217	201	181	159	133	

● Installation sketch

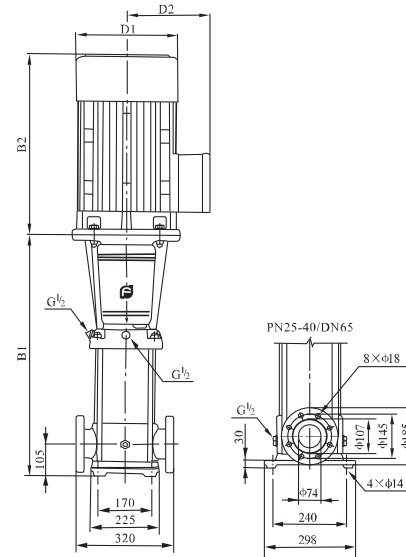

● Size and weight

Model	Size (mm)					Weight (kg)
	B1	B2	B1+B2	D1	D2	
CDL32-10-1	505	345	850	197	165	73
CDL32-10	505	355	860	230	188	81
CDL32-20-2	575	390	965	260	208	95
CDL32-20	575	390	965	260	208	101
CDL32-30-2	645	390	1035	330	255	104
CDL32-30	750	500	1250	330	255	172
CDL32-40-2	820	500	1320	330	255	176
CDL32-40	820	500	1320	330	255	186
CDL32-50-2	890	500	1390	330	255	191
CDL32-50	890	550	1440	330	255	211
CDL32-60-2	960	550	1510	330	255	216
CDL32-60	960	550	1510	330	255	216
CDL32-70-2	1030	575	1605	360	285	255
CDL32-70	1030	575	1605	360	285	255
CDL32-80-2	1100	575	1675	400	310	259
CDL32-80	1100	650	1750	400	310	315
CDL32-90-2	1170	650	1820	400	310	319
CDL32-90	1170	650	1820	400	310	319
CDL32-100-2	1240	650	1890	400	310	324

The overall dimensions of explosion-proof motor is a little different. Pls contact us for details.

● Performance curve ISO9906 Annex A 3500rpm

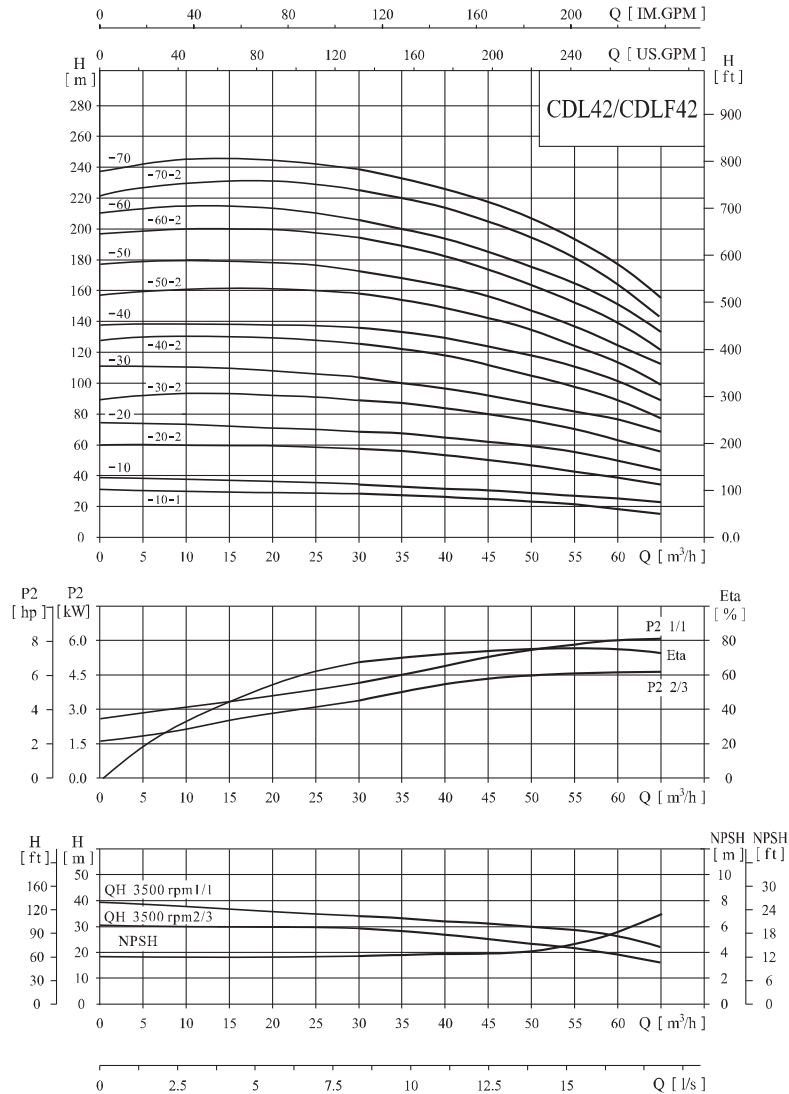

● Performance table

Model	Driving motor		Q (m³/h)	30	35	40	42	45	50	55	60	65
	(kW)	(hp)										
CDL42-10-1	5.5	7.5	H (m)	29	28	27	26	25	23	21	19	16
CDL42-10	7.5	10		34	33	32	31.5	30	29	27	25	22
CDL42-20-2	11	15		57	55	53	52	49	46	43	38	33
CDL42-20	15	20		69	67	65	63	61	59	55	50	44
CDL42-30-2	18.5	25		90	88	85	83	80	75	72	63	55
CDL42-30	18.5	25		102	100	97	95	92	88	82	76	68
CDL42-40-2	22	30		125	121	118	115	112	105	98	89	78
CDL42-40	30	40		136	133	129	126	123	117	112	102	89
CDL42-50-2	30	40		159	154	149	146	142	134	121	115	99
CDL42-50	30	40		171	166	161	158	154	145	138	126	112
CDL42-60-2	37	50		194	188	182	178	173	163	155	139	122
CDL42-60	37	50		205	200	193	190	186	176	166	152	134
CDL42-70-2	45	60		227	220	213	210	205	193	182	165	144
CDL42-70	45	60	239	232	226	221	216	204	194	178	157	

● Installation sketch

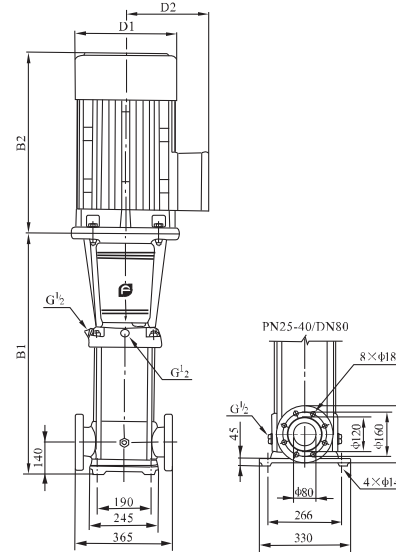

● Size and weight

Model	Size (mm)					Weight (kg)
	B1	B2	B1+B2	D1	D2	
CDL42-10-1	561	390	952	260	208	101
CDL42-10	561	390	952	260	208	106
CDL42-20-2	748	500	1248	330	255	178
CDL42-20	748	500	1248	330	255	188
CDL42-30-2	828	550	1378	330	255	213
CDL42-30	828	550	1378	330	255	213
CDL42-40-2	908	575	1483	360	285	253
CDL42-40	908	650	1558	400	310	309
CDL42-50-2	988	650	1638	400	310	313
CDL42-50	988	650	1638	400	310	313
CDL42-60-2	1068	650	1718	400	310	340
CDL42-60	1068	650	1718	400	310	340
CDL42-70-2	1148	685	1833	460	340	404
CDL42-70	1148	685	1833	460	340	404

The overall dimensions of explosion-proof motor is a little different. Pls contact us for details.

● Performance curve ISO9906 Annex A 3500rpm

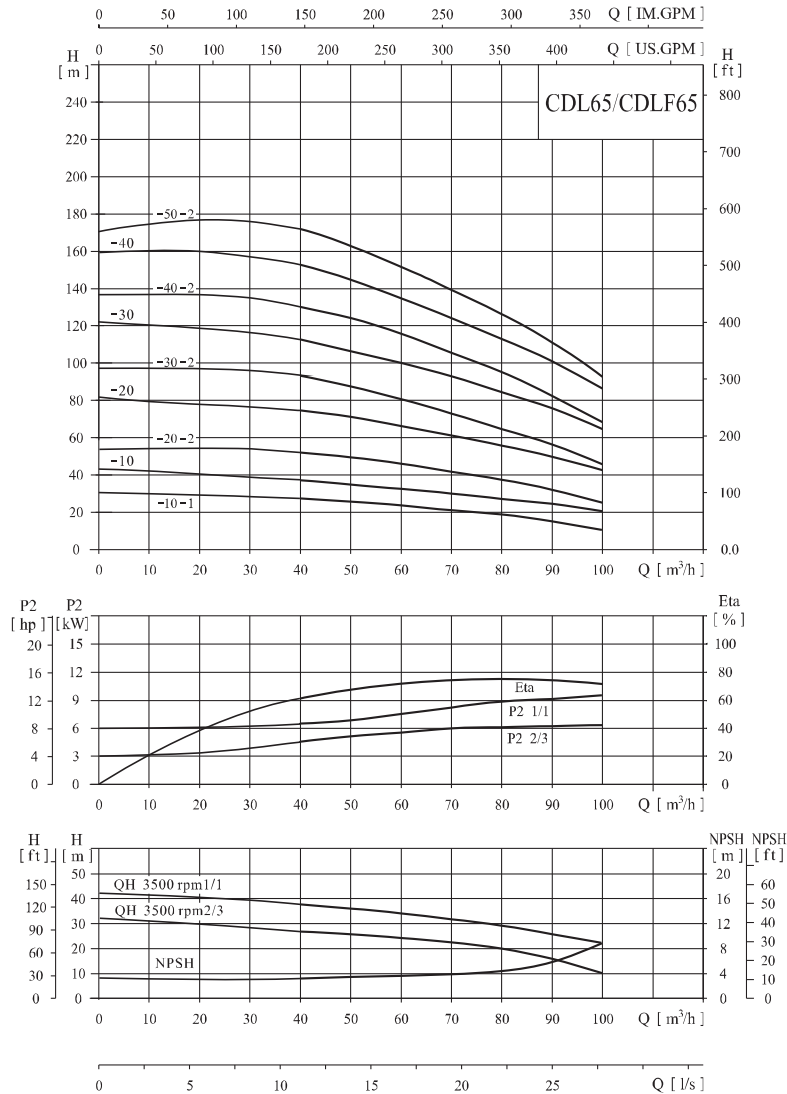

● Performance table

Model	Driving motor		Q (m³/h)	40	50	60	65	70	80	90	100
	(kW)	(hp)									
CDL65-10-1	7.5	10	H (m)	26	25	23	22	21	18	14	10
CDL65-10	11	15		37	35	33	32	31	28	24	21
CDL65-20-2	15	20		53	50	47	44	42	37	31	23
CDL65-20	22	30		74	72	67	64	62	57	51	42
CDL65-30-2	22	30		93	88	80	76	72	65	56	45
CDL65-30	30	40		112	108	100	96	93	86	77	65
CDL65-40-2	37	50		130	124	115	110	103	94	83	66
CDL65-40	45	60		152	144	135	130	123	114	102	86
CDL65-50-2	45	60		172	162	151	144	137	126	112	91

● Installation sketch

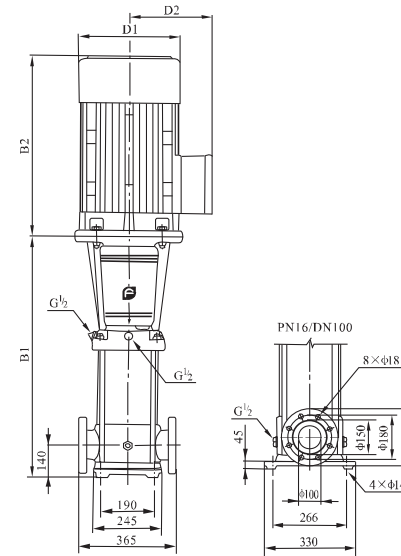

● Size and weight

Model	Size (mm)					Weight (kg)
	B1	B2	B1+B2	D1	D2	
CDL65-10-1	561	390	951	260	208	109
CDL65-10	671	500	1171	330	255	177
CDL65-20-2	754	500	1254	330	255	187
CDL65-20	754	575	1329	360	285	248
CDL65-30-2	836	575	1411	360	285	252
CDL65-30	836	650	1486	400	310	313
CDL65-40-2	919	650	1569	400	310	336
CDL65-40	919	685	1604	460	340	398
CDL65-50-2	1001	685	1686	460	340	402

The overall dimensions of explosion-proof motor is a little different. Pls contact us for details.
(For CDL65 series, PN25-40/DN100 standard flange is also available if required)

● Performance curve ISO9906 Annex A 3500rpm

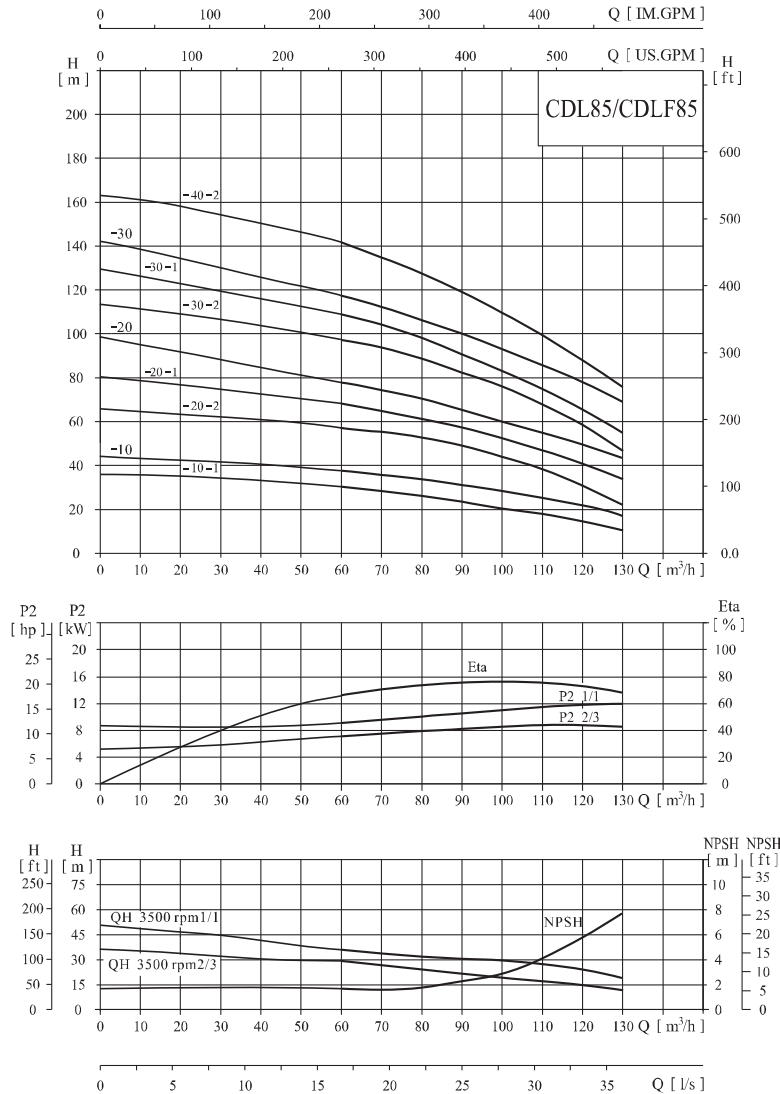

● Performance table

Model	Driving motor		Q (m³/h)	60	70	80	85	90	100	110	120	130
	(kW)	(hp)										
CDL85-10-1	11	15	H (m)	31	27	25	24	23	21	18	14	9
CDL85-10	15	20		36	35	33	31	30	29	26	23	18
CDL85-20-2	18.5	25		59	57	54	51	48	44	39	32	22
CDL85-20-1	22	30		67	65	62	59	57	51	47	41	33
CDL85-20	30	40		76	73	69	66	64	60	56	52	44
CDL85-30-2	37	50		98	94	88	85	82	75	69	59	46
CDL85-30-1	37	50		108	104	98	94	90	83	78	69	56
CDL85-30	45	60		116	111	105	102	97	93	88	79	69
CDL85-40-2	45	60		141	135	128	124	118	109	102	89	72

● Installation sketch

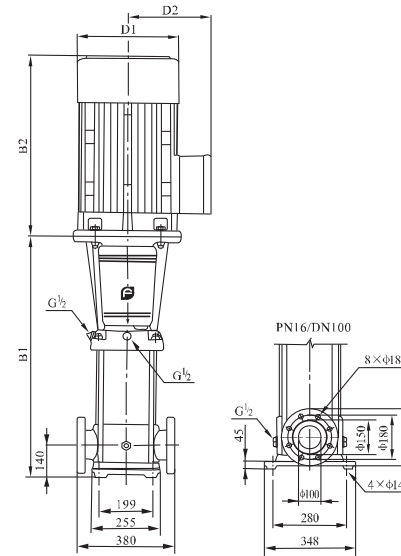

● Size and weight

Model	Size (mm)					Weight (kg)
	B1	B2	B1+B2	D1	D2	
CDL85-10-1	571	500	1071	330	255	177
CDL85-10	571	500	1071	330	255	188
CDL85-20-2	773	550	1323	330	255	211
CDL85-20-1	773	575	1348	360	285	248
CDL85-20	773	650	1423	400	310	304
CDL85-30-2	865	650	1515	400	310	330
CDL85-30-1	865	650	1515	400	310	330
CDL85-30	865	685	1550	460	340	392
CDL85-40-2	957	685	1642	460	340	396

The overall dimensions of explosion-proof motor is a little different. Pls contact us for details.
(For CDL85 series, PN25-40/DN100 standard flange is also available if required)

● Performance curve ISO9906 Annex A 3540rpm

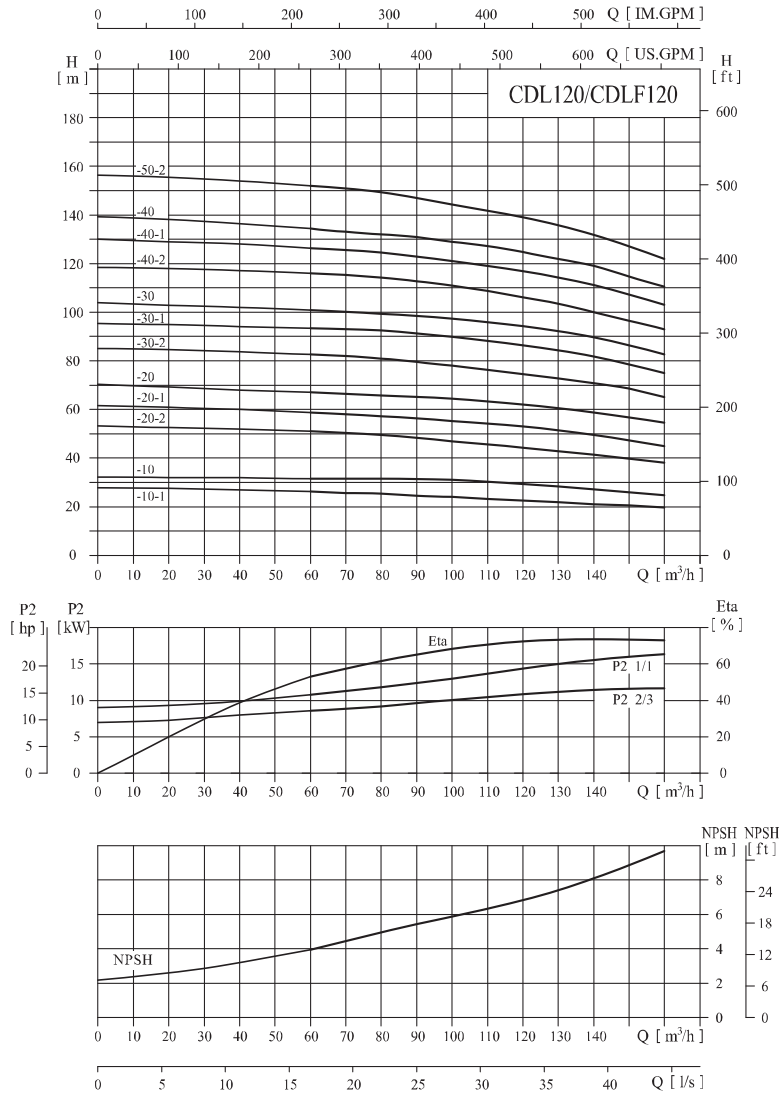

● Performance table

Model	Driving motor		Q (m³/h)	60	70	80	90	100	110	120	130	140	150	160
	(kW)	(hp)												
CDL120-10-1	15	20	H (m)	26.5	26	25	24.5	23.8	23	22.5	21.5	21.3	21	20
CDL120-10	18.5	25		30.8	30.7	30.7	30.5	30.3	29.5	28.8	27.6	26.4	25.4	24.4
CDL120-20-2	30	40		51.5	50.5	49.5	47.5	46	45.5	44.8	43	41	39.7	38.5
CDL120-20-1	30	40		58.3	58	57.3	56	54.7	54	53	51.5	50	47.4	45
CDL120-20	37	50		66.3	66	65.7	65	64.4	63	62	60.7	59.6	57	54.6
CDL120-30-2	45	60		83	82	81	79.5	78	76	74.5	73.5	71	68.5	65
CDL120-30-1	45	60		91.3	91	90.4	89	87.7	86	84.4	82	80	76.7	73.3
CDL120-30	55	75		100.3	100	99.4	98.3	97.3	95.5	94	92	90	86.3	82.7
CDL120-40-2	75	100		116	115.5	114	113	111	109	105.5	104	100	97	93
CDL120-40-1	75	100		126	125.4	124.6	122.6	120.6	118.5	116.5	114	111.3	107	103
CDL120-40	75	100		134	133	132	131	129.5	127.5	125	122	119	114.5	109.5
CDL120-50-2	75	100		152	151	149.7	147	144	141.5	139	135.5	132	127	122

● Installation sketch

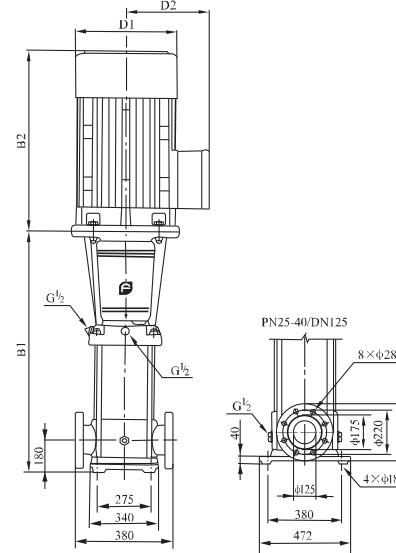

● Size and weight

Model	Size (mm)					Weight (kg)
	B1	B2	B1+B2	D1	D2	
CDL120-10-1	840	500	1340	330	255	235
CDL120-10	840	550	1390	330	255	250
CDL120-20-2	1000	650	1650	400	310	350
CDL120-20-1	1000	650	1650	400	310	350
CDL120-20	1000	650	1650	400	310	380
CDL120-30-2	1160	685	1845	460	340	445
CDL120-30-1	1160	685	1845	460	340	445
CDL120-30	1190	760	1950	510	370	545
CDL120-40-2	1350	845	2195	580	410	675
CDL120-40-1	1350	845	2195	580	410	675
CDL120-40	1350	845	2195	580	410	675
CDL120-50-2	1510	845	2355	580	410	690

The overall dimensions of explosion-proof motor is a little different. Pls contact us for details.

● Performance curve

ISO9906 Annex A 3540rpm

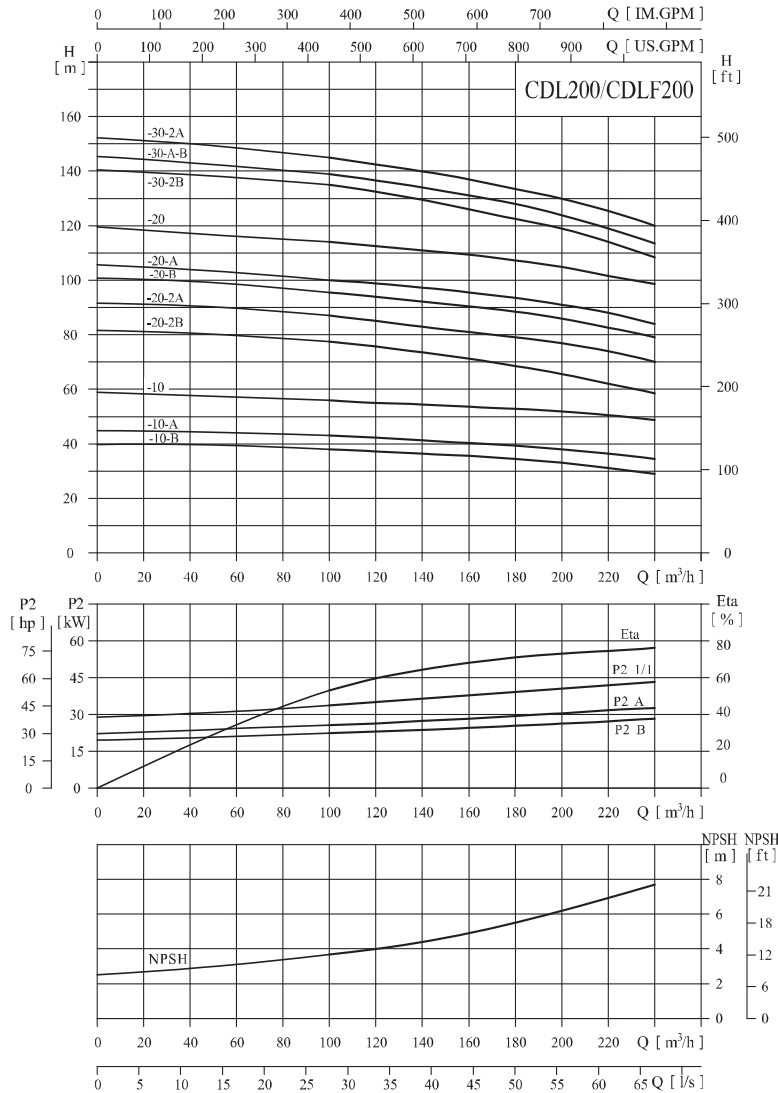

● Performance table

Model	Driving motor		Q (m ³ /h)	H (m)								
	(kW)	(hp)		100	120	140	160	180	200	220	240	
CDL200-10-B	30	40	100	38	37	36.5	35.5	34	33	31	29	
CDL200-10-A	37	50	120	43	42	41.5	40	39	38	36.5	34.5	
CDL200-10	45	60	140	56	55	54.5	53.5	53	52	50.5	48.5	
CDL200-20-2B	55	75	160	77.5	75.5	73.5	71	68.5	66	62	58.5	
CDL200-20-2A	75	100	180	87	85	83	81	79	77	74	70	
CDL200-20-B	75	100	200	95.5	93.5	92.5	90.5	88.5	86	82.5	79	
CDL200-20-A	90	120	220	100	98.5	97.5	95.5	93.5	91	88	84	
CDL200-20	90	120	240	114	112.5	111	109.5	107.5	105	101.5	98.5	
CDL200-30-2B	110	150	100	135	132.5	129.5	126	122.5	119	114	108.5	
CDL200-30-A-B	110	150	120	139	136.5	134	131	128	124	119	113.5	
CDL200-30-2A	110	150	140	145	142.5	140	137	133.5	130	125.5	120	

● Installation sketch

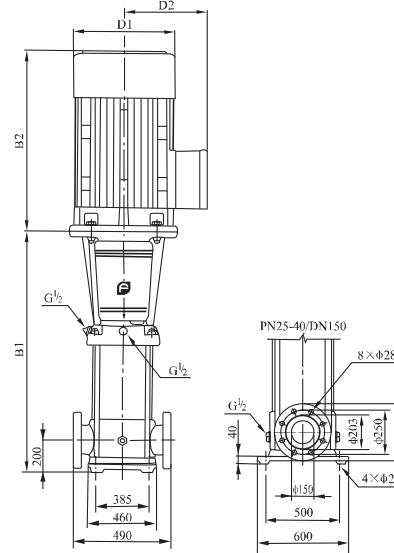

● Size and weight

Model	Size (mm)				Weight (kg)	
	B1	B2	B1+B2	D1		D2
CDL200-10-B	907	650	1557	400	310	403
CDL200-10-A	907	650	1557	400	310	426
CDL200-10	907	685	1592	450	345	484
CDL200-20-2B	1131	760	1891	540	370	595
CDL200-20-2A	1131	845	1976	580	410	718
CDL200-20-B	1131	845	1976	580	410	718
CDL200-20-A	1131	895	2026	580	410	787
CDL200-20	1131	895	2026	580	410	787
CDL200-30-2B	1325	1140	2465	645	550	1158
CDL200-30-A-B	1325	1140	2465	645	550	1158
CDL200-30-2A	1325	1140	2465	645	550	1158

The overall dimensions of explosion-proof motor is a little different. Pls contact us for details.