

# SP

**Non-clogging Self-priming Sewage Pump**



Xrise New Energy Technology Co., Ltd  
Add: Building 1, Industrial Park, South of Baogong Avenue,  
Yaohai District, Hefei, Anhui, China  
Contract: +86 17856275957  
Tel: +551 6467 6468  
Fax: +551 6467 6468  
Email: [helsing@xrisolar.com](mailto:helsing@xrisolar.com)  
Website: [www.xrisolar.com](http://www.xrisolar.com)

E170809  
1500045005  
subject to amendments



# Company Profile



Founded in 1991, Nanfang Pump Industry Co., Ltd. (hereinafter referred to as CNP) has been listed on the Shenzhen Stock Exchange on 9th December 2010; Stock name: CNP; Stock code: 300145.

As the first enterprise specializing in the research and large-scale production of stainless steel stamping welded centrifugal pump in China, CNP is currently the professional manufacturer with the highest volume of production and marketing in that industry. It ranks first in the country in terms of product scope, sales volume, and production quality. The company has set up a complete network of marketing services to meet the requirements of overseas markets as well as domestic needs. The products have seen a wide range of application in the area of pressurization, industry, living water, cycling of air-conditioning water, heat supply, fire extinguishing system, pumping of underground water, treatment of sewage and waste water, chemical industry and desalination of sea water etc.

CNP has now entered into the fast track of development and has taken a major step forward in forging China Strong Pump Enterprise and World's famous brand in the Pump Industry. In order to better meet the client's needs and requirements for expansion, it has set up a wide network of selling and service, as well as offices and service centers in major cities in China, which are aimed at providing timely and effective services for our clients. Meanwhile, our company has successfully penetrated into the world market by forging a good business relationship with more than 50 countries and regions in the Europe, Northern American, and Southeast Asia etc.

# Content

## General Data

Features	3
Operating limits	3
Application	3
Definition of model	4
Installation conditions	4
Section drawing	5
Material	5

## Technical Data

SP-2	6
SP-3	8
SP-4	10
SP-6	12
SP-8	14
SP-10	16
Pump profile & installation dimension	18
Profile & installation dimension of coupled pump set	19
SP pump belt sheave data	20
Profile & installation dimension of $\Delta$ -belt drives pump set	21

## ● Features

SP Non-clogging self-priming sewage pump is our latest developed product, and is suitable for the treatment project of municipal sewage and industrial sewage as well as stage treatment and concentrated treatment system of various sewages. It's known as "King of Self-priming Sewage Pump", and it is the most ideal new-generation sewage product.

- Stable performance, reliable operation.
- Rapid self-priming, high suction head.
- Back-pull-out construction: Convenient for maintenance and troubleshooting. Daily maintenance can be performed rapidly by common tools, saving time and labor.
- Semi-open impeller structure and non-clogging design: Strong passing capacity. Diameter of maximum passing grain for SP-6 is 76mm.
- Convenient usage: The pump can be mounted near cesspit, with only the suction pipe down in the liquid. (The pump shall be filled with water for first start).

## ● Operating limits

- Liquid temperature: 0 °C~40 °C, medium density  $\leq 1.2 \times 10^3 \text{kg/m}^3$ , pH5~9.
- Volume ratio of solids in the medium  $\leq 2\%$ .
- Diameter of maximum grain: SP-2 38mm, SP-3 63mm, SP-4/SP-6/SP-8/SP-10 76mm.
- Ambient temperature:  $\leq 40$  °C.
- Altitude: Max. 1,000m.
- Flow range: 10m<sup>3</sup>/h~750m<sup>3</sup>/h.
- Head range: 3m~38m.
- Power: 1.1kW~90kW.
- Max. Working pressure: See Performance Curve.
- Max. Suction head: See Performance Table.

## ● Application

- Non-flammable and non-explosive liquid.
- Rain water and common sewage.
- Municipal drainage project, construction site, drainage station of people's air defense system.
- Industrial sewage of light industry, paper mill, textile, food processing plant, chemical industry, electric utility, mines, etc.
- Sewage discharge in the residential area.
- Sewage and deposit of water purifying system.
- Tanning industry, sewage of slaughter house, fish breeding in the river and pond.
- Wine and sugar industry.
- Discharge not strongly corrosive but seriously polluted sewage.

## ● Definition of model

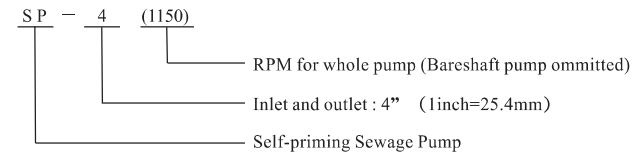

## ● Installation conditions

- Suction pipe can be soft pipe or hard pipe, the material of pipes shall be suitable for the pumped liquid. Soft pipe shall be hard enough to prevent from flat when suction.
- Suction pipe shall be short and straight, use less joints and accessories as less as possible. For joints, the radius shall be bigger.
- The distance between the submersible suction pipe in the sump and the wall of the sump shall be 1.5 times than the radius of the pipe. Suction pipe shall not installed in the sump near the whirlpool. If there is, there shall be one baffle between suction pipe and water. The distance shall be 1.5times than the radius of the pipe..
- If there are two suction in the sump, the pipe distance shall be three times than the radius of the pipe.
- Submersible depth of the submersible suction pipe:

The submersible depth of the suction pipe relates to the flow rate in the pipe. See drawing one

To reduce the submersible depth, we can enlarge the pipe radius or reduce the flow rate of the water. We can use increasing joint to enlarge the radius pipe. The suggested times is 1.3 times to 1.5 times.

- In flooded status, there is inlet pressure. It shall not exceed 50% of the max. working pressure.

- If use the strainer, the face area of the strainer shall be 4 to 6 times than the radius of the pipe. And ensure the max. dia. of the strainer hole to pass granules shall be less than the granule pump allowed.

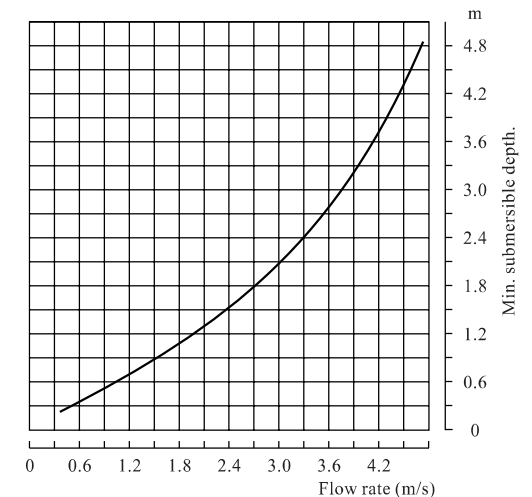

$$\text{Flow rate (m/s)} = \frac{\text{Flow(m}^3\text{/h)}}{\text{Section surface of the pipe(m}^2\text{)}}$$

Suggested suction pipe submersible depth VS flow rate

## Section drawing

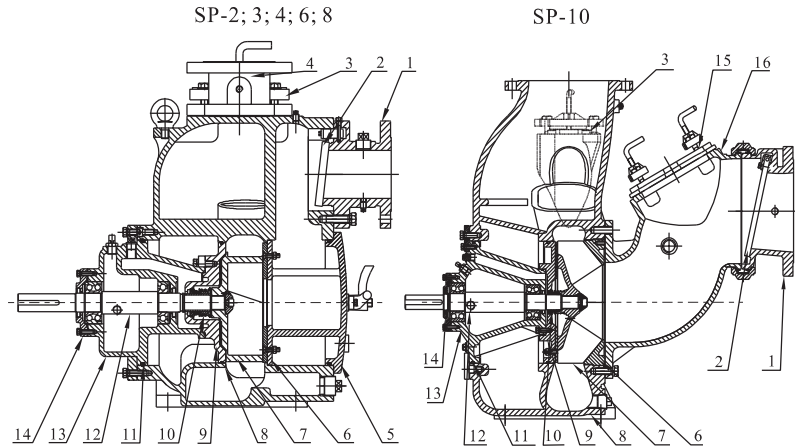

## Material

NO.	Parts	Material
1	Suction Inlet	Cast iron
2	Flap Valve	NBR+ Carbon steel
3	Infusion Cover	Cast iron
4	Discharge Outlet	Cast iron
5	End Cover	Cast iron
6	Wear Plate	Carbon steel
7	Impeller	DCI Cast steel
8	Volute	Cast iron
9	Impeller Cover	Cast iron
10	Mechanical Seal	WC/ WC
11	O-Ring	NBR/FPM
12	Shaft	Stainless steel
13	Bearing Body	Cast iron
14	Bearing Cover	Cast iron
15	Inlet cover	Cast iron
16	Inlet	Cast iron

## Performance curve

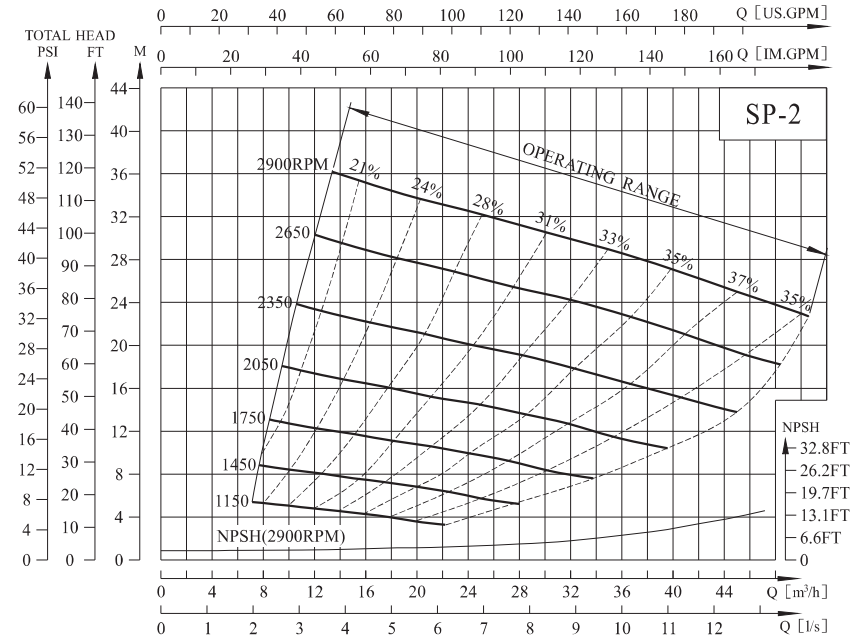

## ● SP-2 Performance Table

Model	RPM	Q		H (m)	Motor		Inlet & Outlet	Max.Solids (mm)	Max.Suction Head (m)
		(m³/h)	(l/s)		(kW)	(HP)			
SP-2	1150	15	4.2	4.0	1.1	1.5	50 (2')	38	5.0
	1450*	20	5.6	6.5	1.5	2			6.5
	1750	25	6.9	9.5	3	4			6.5
	2050	28	7.8	13.5	4	5.5			6.5
	2350	32	8.9	18.0	7.5	10			6.5
	2650	35	9.7	23.0	7.5	10			6.5
	2900*	40	11.1	27.0	9.2	12.5			6.5

## ● SP-2 Operating Table

Model	RPM	Q (m³/h)	H (m)												
			10	12.5	15	17.5	20	25	30	35	40	45			
SP-2	1150	H (m)	5.1	4.7	4.0	3.8	3.5								
	1450*		8.4	8.1	7.6	7.3	6.5	5.8							
	1750		12.6	12.2	11.8	11.3	10.8	9.5	8.5						
	2050		17.9	17.2	16.7	16.1	15.5	14.5	13.2	11.6					
	2350			23.2	22.5	21.8	21.2	19.9	18.6	17.2	15.3				
	2650			30.1	29.2	28.4	27.6	26.2	24.8	23.0	21.6	19.4			
	2900*				35.6	34.5	33.7	32.1	30.4	29	27.0	25.3			

## ● Note: ( Suit for SP-1, 3, 4, 6, 8, 10 )

1)The performance is based on pumping clean water under normal temperature and min suction head is measured on sea level. For different installation way of pump, pump performance vary from flow rate, specific gravity, altitude, temperature. If the specific gravity of pumped medium is bigger than 1.2kg/dm³, please contact us.

2)For the rpm with '\*' in the table, pump can be coupled with YE2 B3 series standard motor.

3)For other rpm, pump can be driven by triangle belt sheave.

## ● Performance curve

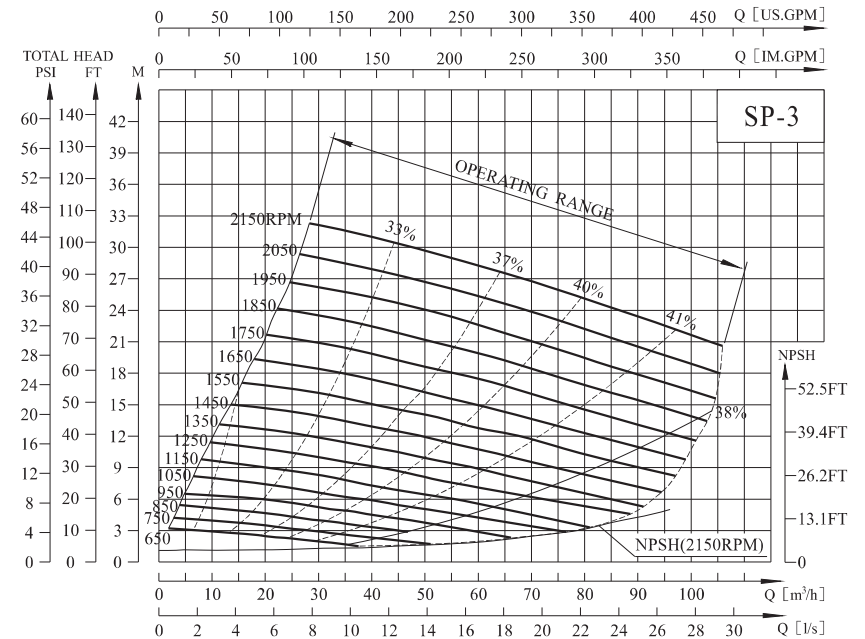

## SP-3 Performance Table

Model	RPM	Q		H (m)	Motor		Inlet & Outlet	Max.Solids (mm)	Max.Suction Head (m)
		(m <sup>3</sup> /h)	(l/s)		(kW)	(HP)			
SP-3	650	25	6.9	2	0.75	1	80 (3')	63	1.5
	750*	30	8.3	3	1.5	2			1.8
	850	32.5	9.0	4	1.5	2			2.4
	950*	40	11.1	4.5	1.5	2			3.0
	1050	42.5	11.8	5.5	3	4			4.0
	1150	45	12.5	7	4	5.5			4.9
	1250	50	13.9	8	4	5.5			5.5
	1350	52.5	14.6	10	5.5	7.5			5.8
	1450*	55	15.3	11.5	5.5	7.5			6.4
	1550	60	16.7	12.5	7.5	10			6.4
	1650	65	18.1	14.5	11	15			6.7
	1750	70	19.4	16	11	15			6.7
	1850	72.5	20.1	18	15	20			7.6
	1950	75	20.8	20	15	20			7.6
	2050	80	22.2	22.5	18.5	25			7.6
	2150	85	23.6	24.5	18.5	25			7.6

## SP-3 Operating Table

Model	RPM	Q (m <sup>3</sup> /h)	H (m)													
			10	20	30	40	50	60	70	80	90	100				
SP-3	650		2.9	2.5	2.0											
	750*		3.9	3.5	3.0	2.3										
	850		5.2	4.7	3.9	3.4										
	950*		6.4	6.0	5.2	4.5	3.8									
	1050		7.9	7.4	6.7	5.9	5.0	4.3								
	1150		9.7	9.0	8.3	7.4	6.5	5.6								
	1250		11.3	10.7	10.0	9.1	8.0	7.1	6.2							
	1350			12.6	11.9	11.0	10.0	9.0	7.7							
	1450*			14.7	14.0	12.9	12.0	10.8	9.6	8.3						
	1550			16.8	16.1	15.1	14.0	12.5	11.7	10.4	9.1					
	1650			19.3	18.5	17.4	16.2	15.0	13.6	12.3	11.1					
	1750				20.9	19.7	18.7	17.5	16.0	14.5	13.2	11.8				
	1850				23.5	22.5	21.2	20.0	18.4	16.9	15.3	14.0				
	1950				26.2	25.3	24.1	22.7	21.0	19.6	17.9	16.4				
	2050				29.0	28.0	26.8	25.3	24.0	22.5	20.5	18.9				
	2150				32.1	31.0	29.7	28.2	26.8	25.1	23.4	21.7				

## Performance curve

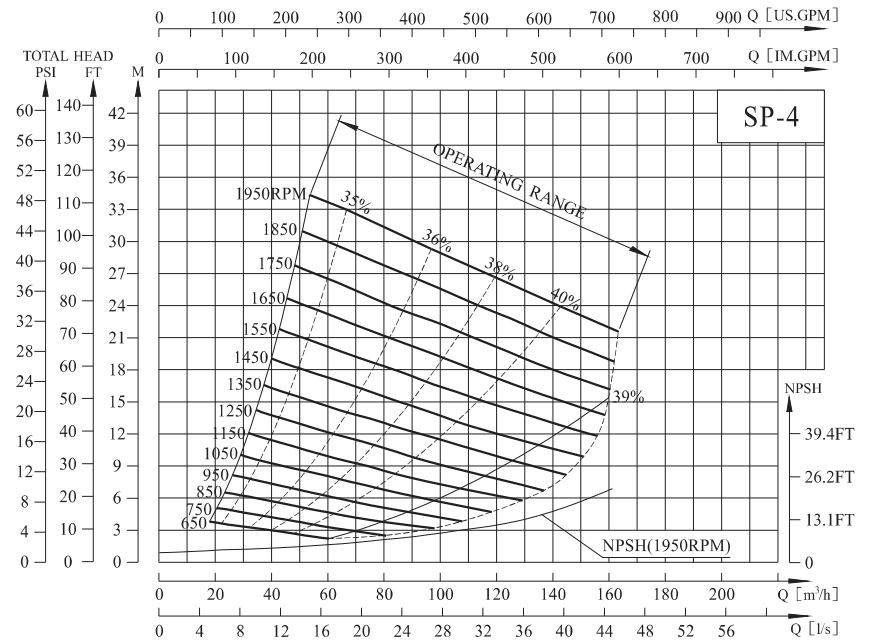

## ● SP-4 Performance Table

Model	RPM	Q		H (m)	Motor		Inlet & Outlet	Max.Solids (mm)	Max.Suction Head (m)
		(m <sup>3</sup> /h)	(l/s)		(kW)	(HP)			
SP-4	650	40	11.1	3	1.5	2	100 (4')	76	1.5
	750*	45	12.5	4	1.5	2			2.4
	850	53	14.7	5	2.2	3			4.9
	950*	60	16.7	6	3	4			5.8
	1050	65	18.1	7.5	5.5	7.5			6.7
	1150	72	20.0	9	5.5	7.5			7.3
	1250	80	22.2	10.5	7.5	10			7.6
	1350	85	23.6	12.5	11	15			7.6
	1450*	100	27.8	13.5	11	15			7.6
	1550	110	30.6	15.5	15	20			7.6
	1650	115	31.9	18	18.5	25			7.6
	1750	120	33.3	20	22	30			7.6
	1850	130	36.1	22.5	30	40			7.6
1950	135	37.5	25	30	40	7.6			

## ● SP-4 Operating Table

Model	RPM	Q (m <sup>3</sup> /h)	H (m)																		
			20	32	48	64	80	96	112	128	144	160									
SP-4	650		3.8	3.3	2.6																
	750*			4.5	3.7	3.0															
	850			6.0	5.3	4.5	3.5														
	950*			7.5	6.5	5.7	5.0														
	1050			9.7	8.7	7.8	6.8	5.9													
	1150			11.9	10.8	9.9	8.8	7.6													
	1250			14.2	13.2	12.0	10.8	9.5	8.4												
	1350			16.7	15.7	14.3	13.1	11.8	10.5												
	1450*				18.0	16.5	15.5	14.0	12.5	11.5											
	1550				20.9	19.8	18.3	16.9	15.4	13.8	12.6										
	1650				24.3	22.9	21.1	19.8	18.1	16.3	15.0										
	1750				27.6	26.2	24.4	22.9	21.3	19.3	17.5	16.2									
	1850				31.0	29.8	27.7	26.1	24.4	22.5	20.5	18.7									
1950				34.5	33.4	31.5	29.4	27.7	25.7	23.5	21.7										

## ● Performance curve

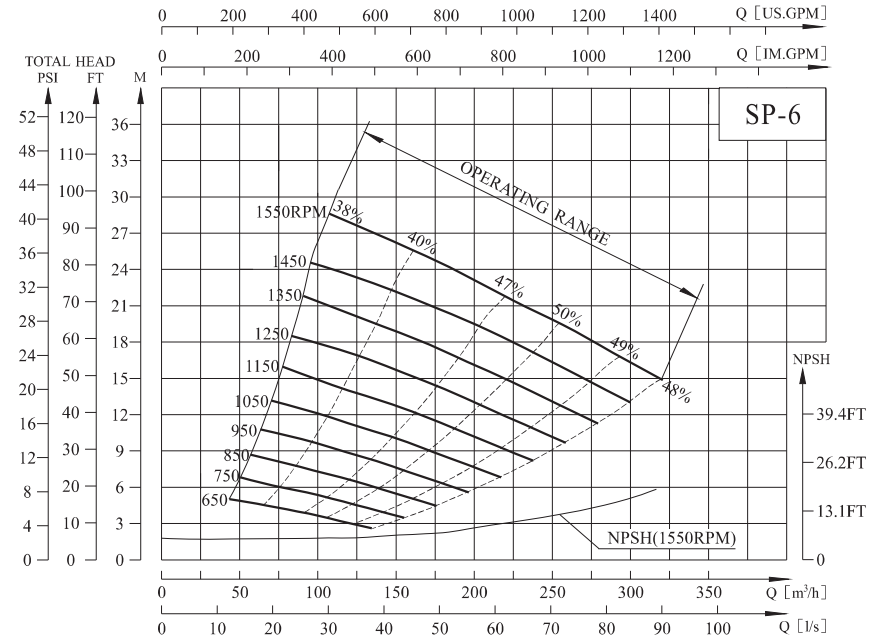

## ● SP-6 Performance Table

Model	RPM	Q		H (m)	Motor		Inlet & Outlet	Max.Solids (mm)	Max.Suction Head (m)
		(m³/h)	(l/s)		(kW)	(HP)			
SP-6	650	100	27.8	3.5	3	4	150 (6')	76	2.4
	750*	125	34.7	4.5	4	5.5			2.7
	850	150	41.7	5.5	7.5	10			3.6
	950*	160	44.4	7.5	7.5	10			4.2
	1050	180	50.0	9.0	11	15			5.5
	1150	200	55.6	10.0	15	20			6.4
	1250	220	61.1	12.5	22	30			6.4
	1350	230	63.9	15.0	30	40			6.7
	1450*	250	69.4	17.0	30	40			7.0
1550	280	77.8	18.0	37	50	7.6			

## ● SP-6 Operating Table

Model	RPM	Q (m³/h)	H (m)													
			50	80	120	150	180	210	240	270	300					
SP-6	650	H (m)	5.0	4.2	3.1											
	750*			6.0	4.7	3.6										
	850			8.0	7.0	5.5										
	950*			11.0	9.5	7.5	6.8									
	1050			13.0	11.0	10.0	9.0	7.5								
	1150			16.0	14.0	12.8	11.2	10.0	8.0							
	1250					17.0	15.5	14.0	12.7	10.5						
	1350						20.5	19.0	17.5	15.5	14.0	12.0				
	1450*							24.0	22.0	21.0	19.0	17.0	15.0	13.0		
1550							28.0	26.0	24.5	22.7	20.5	18.5	16.5			

## ● Performance curve

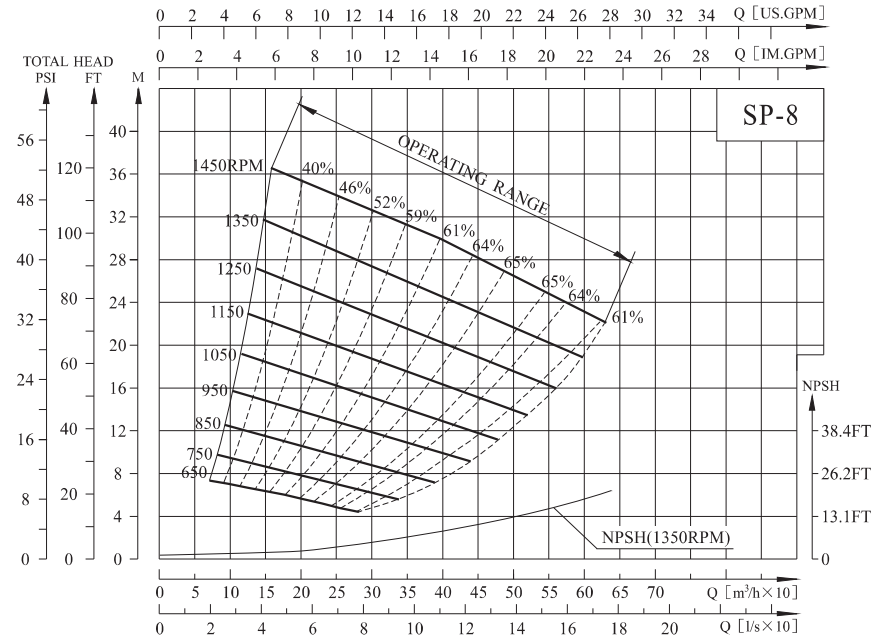



## ● SP-8 Performance Table

Model	RPM	Q		H (m)	Motor		Inlet & Outlet	Max.Solids (mm)	Max.Suction Head (m)
		(m <sup>3</sup> /h)	(l/s)		(kW)	(HP)			
SP-8	650	200	55.6	6	7.5	10	200 (8')	76	2.7
	750*	230	63.9	8	11	15			3.7
	850	260	72.2	10	15	20			4.6
	950*	300	83.3	12	22	30			5.2
	1050	320	88.9	15	30	41			6.1
	1150	350	97.2	18	37	50			6.4
	1250	400	111.1	20	55	75			6.7
	1350	450	125.0	23	75	102			7
1450*	500	138.9	26	75	102	7			

## ● SP-8 Operating Table

Model	RPM	Q (m <sup>3</sup> /h)	H (m)												
			100	150	200	250	300	350	400	450	500	580			
SP-8	650	H (m)	7.0	6.5	6.0	5.0									
	750*		8.8	8.5	7.5	6.5									
	850		11.5	11.0	10.0	9.0	8.0								
	950*		15.0	14.0	13	12.0	11.0								
	1050		18.5	17.5	16.5	15.5	14.0	13.0							
	1150			21.5	20.3	19.0	18.0	16.5	15.5						
	1250			25.5	24.5	23.0	22.0	20.0	19.0	18.0					
	1350			30.5	29.0	27.8	26.0	25.0	23.0	22.0					
1450*			35.5	34.0	32.0	31.0	30.0	28.0	26.0	23.0					

## ● Performance curve

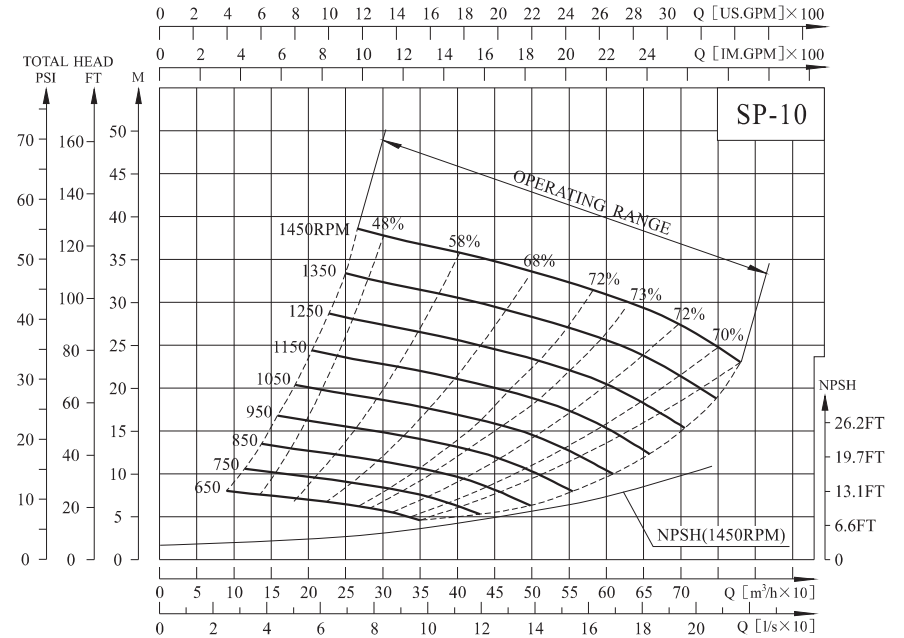

## SP-10 Performance Table

Model	RPM	Q		H (m)	Motor		Inlet & Outlet	Max.Solids (mm)	Max.Suction Head (m)
		(m³/h)	(l/s)		(kW)	(HP)			
SP-10	650	250	69	6.5	11	15	250 (10')	76	2.1
	750*	300	83	8.5	15	20			3.4
	850	350	97	11	22	30			4.3
	950*	400	111	13	30	41			5.2
	1050	450	125	16	45	61			5.5
	1150	500	139	19	55	75			5.5
	1250	525	146	23	75	102			5.8
	1350	550	153	27	90	122			6.7
1450*	600	167	31	90	122	6.7			

## SP-10 Operating Table

Model	RPM	Q (m³/h)	H (m)										
			200	300	400	450	500	550	600	650	700	750	
SP-10	650	H (m)	7.0	6.5									
	750*		10.0	8.5	6.0								
	850		13.0	11.5	10.0	8.0							
	950*		16.0	15.0	13.0	12.0	10.0						
	1050		20.0	19.0	17.0	16.0	14.5	12.5					
	1150			23.0	21.0	20.0	19.0	17.5	15.0				
	1250			27.5	25.5	24.5	23.5	22.0	20.5	18.0			
	1350			32.5	30.5	29.5	28.0	27.0	25.5	23.5	21.5		
1450*		38.0	36.0	35.0	33.5	32.0	31.0	29.5	27.5	24.5			

## Pump profile & installation dimension

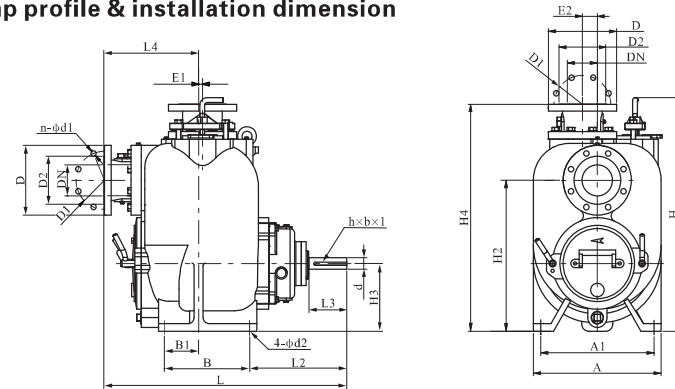

Item	SP-2	SP-3	SP-4	SP-6	SP-8	SP-10
PN	PN0.6MPa / Class 150 lb		PN1.0MPa / Class 150 lb		PN1.6MPa / Class 150 lb	
DN	50/2'	80/3'	100/4'	150/6'	200/8'	250/10'
D	140/6'	190/7.5'	228.6/9'	285/11'	340/13.5'	405/16'
D1	110/4.75'	150/6'	180/7.5'	240/9.5'	295/11.75'	355/14.25'
D2	90/3.6'	127/5'	158/6.19'	212/8.3'	266/10.62'	320/12.75'
n-d1	4-14/0.75'	4-19/0.75'	8-19/0.75'	8-23/0.88'	8-23/0.88'	12-26/1'
h x b x 1	10 x 5 x 95	10 x 5 x 80	10 x 5 x 90	10 x 5 x 95	14 x 3.5 x 127	14 x 3.5 x 120
	0.38' x 0.19' x 3.74'	0.38' x 0.19' x 3'	0.38' x 0.19' x 3.5'		0.38' x 0.19' x 5'	
H2	318/12.51'	431.8/17'	495.3/19.5'	574.3/22.61'	723.8/28.5'	639.8/25.19'
A	308/12.13'	377/14.84'	428/16.85'	580/22.83'	716/28.19'	705/27.75'
A1	281/11.06'	328/12.91'	373/14.69'	527/20.75'	635/25'	635/25'
B	163.2/6.42'	228.6/9'	279.4/11'	279.4/11'	304.8/12'	304.8/12'
B1	54/2.12'	76.2/3'	110/4.33'	77.8/3.06'	101.6/4'	101.6/4'
L2	274.8/10.82'	285/11.22'	326/12.83'	294/11.57'	407.1/16.03'	320.6/12.63'
d2	14/0.55'	18/0.71'	18/0.71'	18/0.71'	24/0.88'	24/0.88'
H3	151.5/5.96'	190.5/7.5'	222.2/8.75'	257.2/10.13'	330.2/13'	355.6/14'
L3	104/4.09'	102/4.02'	127/5'	127/5'	170/6.69'	123/4.84'
d	38/1.50'	38/1.5'	38/1.5'	38/1.5'	48/1.75'	48/1.75'
H	552/21.73'	697.5/27.46'	760/29.92'	875/34.45'	989/38.94'	1017/40.04'
Am	321/12.64'	389/15.31'	429/16.89'	580/22.83'	716/28.19'	786/30.94'
H4	502/19.16'	652/25.67'	735/28.94'	887.7/34.95'	1069.3/42.06'	1047.8/41.25'
L	615/24.21'	712.2/28.04'	813.5/32.03'	906.6/35.69'	1023/40.28'	1244.7/49'
L4	233/9.17'	277/10.91'	318/12.52'	411/16.18'	412.8/16.25'	720.9/28.38'
E1	27.5/1.08'	15/0.59'	13/0.51'	0	0	0
E2	70/2.76'	50/2'	50/2'	50/2'	0	0
Wt. (kg/lbs)	99/218	190/419	275/606	438/966	655/1445	705/1555

## ● Profile & installation dimension of coupled pump set

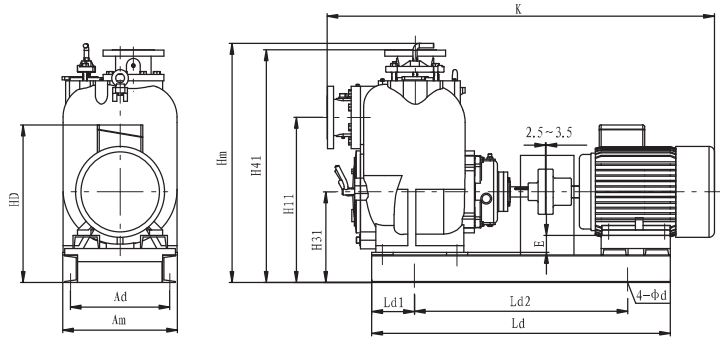

Model	Motor		Dimensions							Dimensions						
	Power (kW)	Model	Ad	Ld1	Ld2	d	H11	H31	H41	K	Am	Hm	HD	E	Ld	
SP-2(1450)	1.5	YE2-90L-4	300	77.5	617	20	428	261.5	612	986	341	662	416.5	61.5	772	
SP-2(2900)	9.2	YE2-132S-2	300	77.5	695	20	428	261.5	612	1110	341	662	471.5	19.5	850	
SP-3(750)	1.5	YE2-112M-8	330	120	621	20	541.8	300.5	762.2	1134	370	800	490.5	78.5	861	
SP-3(950)	1.5	YE2-100L-6	330	120	614	20	541.8	300.5	762.2	1119	370	800	480.5	90.5	854	
SP-3(1450)	5.5	YE2-132S1-4	330	120	660	20	541.8	300.5	762.2	1204	370	800	510.5	58.5	900	
SP-4(750)	1.5	YE2-112M-8	370	150	663	20	605.3	332.2	843.6	1236	430	887.3	522.2	110.2	963	
SP-4(950)	3	YE2-132S-6	370	150	702	20	605.3	332.2	843.6	1306	430	887.3	542.2	90.2	1002	
SP-4(1450)	11	YE2-160M-4	370	150	821	20	605.3	332.2	843.6	1451	430	887.3	587.2	62.2	1121	
SP-6(750)	4	YE2-160M1-8	510	150	784	20	710.3	393.2	1023.7	1544	590	1024	648.2	97.2	1084	
SP-6(950)	7.5	YE2-160M-6	510	150	784	20	710.3	393.2	1023.7	1544	590	1024	648.2	97.2	1084	
SP-6(1450)	30	YE2-200L-4	510	150	905	20	710.3	393.2	1023.7	1705	590	1024	698.2	57.2	1205	
SP-8(750)	11	YE2-180L-8	640	150	1050	24	904	510.2	1250	1767	716	1250	790	150.2	1350	
SP-8(950)	22	YE2-200L2-6	640	150	1085	24	904	510.2	1250	1769	716	1250	815	130.2	1385	
SP-8(1450)	75	YE2-280S-4	640	150	1264	24	904	510.2	1250	2012	716	1250	1020	50.2	1564	
SP-10(750)	15	YE2-200L-8	640	150	1050	24	820	535.6	1227.8	2020	786	1228	880.6	155.6	1350	
SP-10(950)	30	YE2-225M-6	640	150	1050	24	820	535.6	1227.8	2095	786	1228	865.6	130.6	1350	
SP-10(1450)	90	YE2-280M-4	640	150	1240	24	820	535.6	1227.8	2285	786	1228	935.6	75.6	1540	

## ● SP pump belt sheave data

Model	Motor		Belt sheave at motor end		Belt sheave at pump end		Triangle belt		
	Power (kW)	Model	Model	OD of belt sheave (mm)	Model	OD of belt sheave (mm)	Model	Fiducial length	Nos.
SP-2(1150)	1.1	YE2-90S-4	VA2-85	90.5	VA2-100	105.5	Belt A	990	2
SP-2(1750)	3	YE2-100L-2	VA3-85	90.5	VA3-132	137.5	Belt A	990	3
SP-2(2050)	4	YE2-112M-2	VA3-100	105.5	VA3-132	137.5	Belt A	1100	3
SP-2(2350)	7.5	YE2-132S2-2	VA4-100	105.5	VA4-120	125.5	Belt A	1250	4
SP-2(2650)	7.5	YE2-132S2-2	VA3-118	123.5	VA3-125	130.5	Belt A	1250	3
SP-3(650)	0.75	YE2-80M2-4	VA2-80	85.5	VA2-160	165.5	Belt A	1250	2
SP-3(850)	1.5	YE2-90L-4	VA2-80	85.5	VA2-125	130.5	Belt A	1250	2
SP-3(1050)	3	YE2-100L2-4	VA3-90	95.5	VA3-120	125.5	Belt A	1250	3
SP-3(1150)	4	YE2-112M-4	VA3-100	105.5	VA3-120	125.5	Belt A	1430	3
SP-3(1250)	4	YE2-112M-4	VA3-100	105.5	VA3-112	117.5	Belt A	1430	3
SP-3(1350)	5.5	YE2-132S1-4	VA4-125	130.5	VA4-130	135.5	Belt A	1430	4
SP-3(1550)	7.5	YE2-132S2-2	VA3-125	130.5	VA3-224	229.5	Belt A	1430	3
SP-3(1650)	11	YE2-160M1-2	VA4-125	130.5	VA4-212	217.5	Belt A	1560	4
SP-3(1750)	11	YE2-160M1-2	VA4-125	130.5	VA4-200	205.5	Belt A	1560	4
SP-3(1850)	15	YE2-160M2-2	VB4-132	139	VB4-200	207	Belt B	1560	4
SP-3(1950)	15	YE2-160M2-2	VB4-125	132	VB4-180	187	Belt B	1560	4
SP-3(2050)	18.5	YE2-160L-2	VB4-160	167	VB4-224	231	Belt B	1560	4
SP-3(2150)	18.5	YE2-160L-2	VB4-160	167	VB4-212	219	Belt B	1560	4
SP-4(650)	1.5	YE2-90L-4	VA2-85	90.5	VA2-180	185.5	Belt A	1430	2
SP-4(850)	2.2	YE2-100L1-4	VA3-90	95.5	VA2-150	155.5	Belt A	1430	2
SP-4(1050)	5.5	YE2-132S-4	VA3-125	130.5	VA3-160	165.5	Belt A	1550	3
SP-4(1150)	5.5	YE2-132S-4	VA3-125	130.5	VA3-150	155.5	Belt A	1550	3
SP-4(1250)	7.5	YE2-132M-4	VA4-125	130.5	VA4-140	145.5	Belt A	1550	4

## SP pump belt sheave data

Model	Motor		Belt sheave at motor end		Belt sheave at pump end		Triangle belt		
	Power (kW)	Model	Model	OD of belt sheave (mm)	Model	OD of belt sheave (mm)	Model	Fiducial length	Nos.
SP-4(1350)	11	YE2-160M-4	VB4-160	167	VB4-170	177	Belt B	1560	4
SP-4(1550)	15	YE2-160M2-2	VB3-180	187	VB3-315	322	Belt B	1950	3
SP-4(1650)	18.5	YE2-160L-2	VB4-150	157	VB4-250	257	Belt B	1950	4
SP-4(1750)	22	YE2-180M-2	VB4-180	187	VB4-280	287	Belt B	1950	4
SP-4(1850)	30	YE2-200L1-2	VC4-212	209.6	VC4-315	324.6	Belt C	1950	4
SP-4(1950)	30	YE2-200L1-2	VC4-250	239.6	VC4-355	364.6	Belt C	1950	4
SP-6(650)	3	YE2-100L2-4	VA2-85	91	VA2-180	186	Belt A	1550	2
SP-6(850)	7.5	YE2-132M-4	VB4-125	132	VB4-200	207	Belt B	1760	4
SP-6(1050)	11	YE2-160M-4	VB3-170	177	VB3-224	231	Belt B	1950	3
SP-6(1150)	15	YE2-160L-4	VB4-170	177	VB4-200	207	Belt B	1950	4
SP-6(1250)	22	YE2-180L-4	VC4-224	234	VC4-250	260	Belt C	1950	4
SP-6(1350)	30	YE2-200L-4	VC4-250	260	VC4-265	275	Belt C	2195	5
SP-6(1550)	37	YE2-225S-4	VC4-300	310	VC4-280	290	Belt C	2195	4
SP-8(650)	7.5	YE2-160M-6	VB3-125	132	VB3-180	187	Belt B	1950	3
SP-8(850)	15	YE2-180L-6	VB4-200	207	VB4-224	231	Belt B	1950	4
SP-8(1050)	30	YE2-200L-4	VC4-224	233.6	VC4-315	324.6	Belt C	2420	4
SP-8(1150)	37	YE2-225S-4	VC4-280	289.6	VC4-355	364.6	Belt C	2420	4
SP-8(1250)	55	YE2-250M-4	VC4-280	289.6	VC4-315	324.6	Belt C	2420	4
SP-8(1350)	75	YE2-280S-4	VD4-355	371.2	VD4-375	391.2	Belt D	2740	4
SP-10(650)	11	YE2-160L-6	VB4-140	147	VB4-200	207	Belt B	1950	4
SP-10(850)	22	YE2-200L2-6	VC4-224	233.6	VC4-250	259.6	Belt C	2195	4
SP-10(1050)	45	YE2-225M-4	VC4-250	259.6	VC4-355	364.6	Belt C	2420	4
SP-10(1150)	55	YE2-250M-4	VC4-315	324.6	VC4-400	409.6	Belt C	2715	4
SP-10(1250)	75	YE2-280S-4	VD4-355	371.2	VD4-425	441.2	Belt D	2740	4
SP-10(1350)	90	YE2-280M-4	VD4-355	371.2	VD4-375	391.2	Belt D	2740	4

Note for table: Belt sheave complies with GB/T10412 rule; belt complies with GB/T 11544 rule.

## Profile & installation dimension of $\Delta$ -belt drives pump set

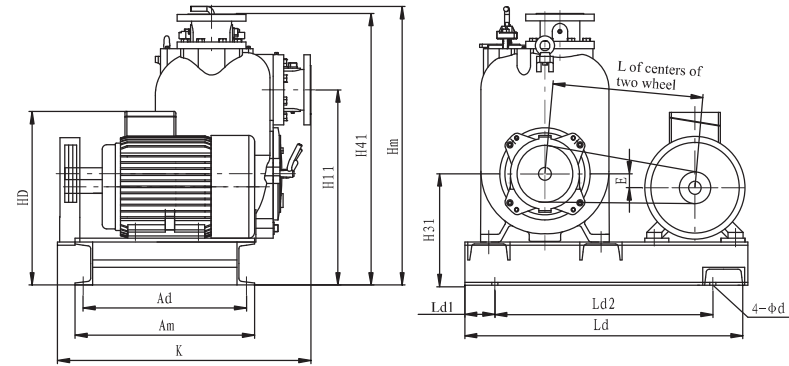

Model	Motor		Dimensions								Dimensions					
	Power (kW)	Model	Ad	Ld1	Ld2	d	H11	H31	H41	L	Ld	K	Hm	Am	HD	E
SP-2(1150)	1.1	YE2-90S-4	375	100	515	20	438	271.5	622	350	715	655	672	423	375	72
SP-2(1750)	3	YE2-100L-2	359	100	550	20	438	271.5	622	375	750	655	672	407	410	62
SP-2(2050)	4	YE2-112M-2	352	100	560	20	438	271.5	622	363	760	655	672	400	432	50
SP-2(2350)	7.5	YE2-132S2-2	313	100	670	20	438	271.5	622	451	870	655	672	361	472	30
SP-2(2650)	7.5	YE2-132S2-2	313	100	650	20	438	271.5	622	433	850	655	672	361	472	30
SP-3(650)	0.75	YE2-80M2-4	467	100	609	20	552	310.5	772	428	808	752	818	514	355	121
SP-3(850)	1.5	YE2-90L-4	451	100	651	20	552	310.5	772	460	854	752	818	498	375	111
SP-3(1050)	3	YE2-100L2-4	435	100	662	20	552	310.5	772	459	866	752	818	482	410	101
SP-3(1150)	4	YE2-112M-4	428	100	767	20	552	310.5	772	540	967	752	818	475	432	89
SP-3(1250)	4	YE2-112M-4	428	100	774	20	552	310.5	772	548	974	752	818	475	432	89
SP-3(1350)	5.5	YE2-132S1-4	389	100	756	20	552	310.5	772	514	956	752	818	436	472	69
SP-3(1550)	7.5	YE2-132S2-2	389	100	675	20	552	310.5	772	434	875	752	818	436	472	69
SP-3(1650)	11	YE2-160M1-2	341	100	776	20	552	310.5	772	509	975	752	818	389	545	41
SP-3(1750)	11	YE2-160M1-2	341	100	786	20	552	310.5	772	519	986	752	818	389	545	41
SP-3(1850)	15	YE2-160M2-2	341	100	781	20	552	310.5	772	514	981	752	818	389	545	41
SP-3(1950)	15	YE2-160M2-2	341	100	803	20	552	310.5	772	536	1003	752	818	389	545	41
SP-3(2050)	18.5	YE2-160L-2	341	100	744	20	552	310.5	772	477	944	752	818	389	545	41
SP-3(2150)	18.5	YE2-160L-2	341	100	753	20	552	310.5	772	486	953	752	818	389	545	41

# Technical Data

## ● Profile & installation dimension of $\triangle$ -belt drives pump set

Model	Motor		Dimensions								Dimensions					
	Power (kW)	Model	Ad	Ld1	Ld2	d	H11	H31	H41	L	Ld	K	Hm	Am	HD	E
SP-4(650)	1.5	YE2-90L-4	545	100	722	20	635.3	362.2	875	499	922	855	900	600	395	142.2
SP-4(850)	2.2	YE2-100L1-4	529	100	761	20	635.3	362.2	875	525	961	855	900	584	430	132.2
SP-4(1050)	5.5	YE2-132S-4	483	100	818	20	635.3	362.2	875	543	1018	855	900	538	492	100.2
SP-4(1150)	5.5	YE2-132S-4	483	100	830	20	635.3	362.2	875	555	1030	855	900	538	492	100.2
SP-4(1250)	7.5	YE2-132M-4	483	100	840	20	635.3	362.2	875	565	1040	855	900	538	492	100.2
SP-4(1350)	11	YE2-160M-4	436	100	818	20	635.3	362.2	875	521	1018	855	900	491	565	72.2
SP-4(1550)	15	YE2-160M2-2	436	100	876	20	635.3	362.2	875	567	1076	855	900	491	565	72.2
SP-4(1650)	18.5	YE2-160L-2	436	100	959	20	635.3	362.2	875	649	1159	855	900	491	565	72.2
SP-4(1750)	22	YE2-180M-2	423	100	922	20	635.3	362.2	875	599	1122	855	900	478	610	52.2
SP-4(1850)	30	YE2-200L1-2	413	100	900	20	635.3	362.2	875	547	1100	855	900	468	655	32.2
SP-4(1950)	30	YE2-200L1-2	413	100	870	20	635.3	362.2	875	526	1070	855	900	468	655	32.2
SP-6(650)	3	YE2-100L2-4	497	100	886	20	714.3	397.2	1027.7	562	1096	947	1030	552	462	135.2
SP-6(850)	7.5	YE2-132M-4	451	100	970	20	714.3	397.2	1027.7	618	1180	947	1030	506	492	135.2
SP-6(1050)	11	YE2-160M-4	404	100	1045	20	714.3	397.2	1027.7	659	1255	947	1030	459	565	107.2
SP-6(1150)	15	YE2-160L-4	404	100	1061	20	714.3	397.2	1027.7	675	1271	947	1030	459	565	107.2
SP-6(1250)	22	YE2-180L-4	391	100	1013	20	714.3	397.2	1027.7	596	1223	947	1030	446	610	87.2
SP-6(1350)	30	YE2-200L-4	381	100	1130	20	714.3	397.2	1027.7	692	1340	947	1030	436	655	67.2
SP-6(1550)	37	YE2-225S-4	335	100	1127	20	714.3	397.2	1027.7	662	1337	947	1030	390	710	42.2
SP-8(650)	7.5	YE2-160M-6	614	150	1060	24	924	530.2	1269.3	733	1375	1043	1270	675	615	170.2
SP-8(850)	15	YE2-180L-6	599	150	1000	24	924	530.2	1269.3	642	1315	1043	1270	660	660	150.2
SP-8(1050)	30	YE2-200L-4	599	150	1200	24	924	530.2	1269.3	792	1515	1054	1270	660	705	130.2
SP-8(1150)	37	YE2-225S-4	549	150	1130	24	924	530.2	1269.3	712	1445	1054	1270	610	760	105.2
SP-8(1250)	55	YE2-250M-4	549	150	1150	24	924	530.2	1269.3	735	1465	1054	1270	610	820	80.2
SP-8(1350)	75	YE2-280S-4	514	150	1260	24	924	530.2	1269.3	792	1575	1095	1270	575	890	50.2
SP-10(650)	11	YE2-160L-6	529	150	1040	24	839.8	555.6	1247.8	704	1375	1270	1248	590	615	195.6
SP-10(850)	22	YE2-200L2-6	509	150	1100	24	839.8	555.6	1247.8	725	1435	1280	1248	570	705	155.6
SP-10(1050)	45	YE2-225M-4	459	150	1180	24	839.8	555.6	1247.8	743	1515	1280	1248	520	760	130.6
SP-10(1150)	55	YE2-250M-4	489	150	1280	24	839.8	555.6	1247.8	798	1615	1280	1248	550	820	105.6
SP-10(1250)	75	YE2-280S-4	539	150	1280	24	839.8	555.6	1247.8	738	1615	1320	1248	600	890	75.6
SP-10(1350)	90	YE2-280M-4	554	150	1280	24	839.8	555.6	1247.8	792	1615	1320	1248	615	890	75.6

## MEMO

.....

.....

.....

.....

.....

.....

.....

.....

.....

.....

.....

.....

.....

.....

.....

.....

.....

.....

.....

.....

.....

.....